



Installation Instructions

Kit, Base Rail Bracket Part # 31413

Dealer / Installer: Provide a copy of these Instructions to the end user of this product. These Instructions provide important operating and safety information for proper usage of this product. Demonstrate the proper use of the product with the end user. Have the end user demonstrate that they understand the proper use of the product.

End User: Read and follow all instructions included in this manual. Ask your Dealer / Installer for assistance if you do not understand the proper use of the product. Never remove any warning decals from the product.

*APPLICATION: 2003 – 2008 Dodge Ram 1500, 2003- 2012 Dodge Ram 2500 HD, 3500 HD Pick-Up
(Includes all Megacab Trucks) (Excludes 06 Ram 1500)*

NOTE: This bracket kit is to be used with the 31323 Bed Rail Kit.

Complete Parts List			
Item No.	Part No.	Description	Quantity
1	ERD10333	Bracket, Front Left - Weldment	1
2	ERD10329	Bracket, Front Left Clamp	1
3	ERD10334	Bracket, Front Right - Weldment	1
4	ERD10330	Bracket, Front Right Clamp	1
5	ERD10339	Bracket, Left Rear Mount	1
6	ERD10340	Bracket, Right Rear Mount	1
7	ERD10345	Spacer, U-Bracket	1
8	ERD10031	Spacer, Plate 3/4"	4
9	ERD10344	Spacer, Tube - Weldment	2
10	ERD10020	Plate, Spacer	4
11	ERD10346	U-Bolt, 1/2 -13 X 5-1/2"	1
12	ERD10347	U-Bolt, 1/2 -13 X 6-1/2"	2
13	ERD12154	Washer, Flat (1/2)	8
14	ERD12201	Nut, Nylon Lock (1/2 -13)	8
15	ERD10678	Bolt, Carriage 1/2 -13 X 5"	4
16	ERD10390	Bolt, Hex 5/8 -11 X 3"	2
17	ERD10677	Bolt, Hex 5/8 -11 X 5-1/2"	2
18	ERD12188	Washer, Flat (5/8)	4
19	ERD10531	Washer, Flat Standard (5/8)	2
20	ERD12187	Washer, Lock (5/8)	4
21	ERD12184	Nut, Hex (5/8 -11)	2

Tools Required	
3/4" Socket & Wrench	1/4" Drill Bit
15/16" Socket & Wrench	9/16" Drill Bit
Drill	5/8" Drill Bit
Torque Wrench	3/4" Drill Bit
Safety Glasses	13MM Socket
Ratchet Extension	Pry Bar

Caution: Do not install mounting rails over plastic bed liners. Plastic bed liners must be cut out of the way. Rails may be installed on spray in liners.

Note: Consult spray liner installer for recommended curing time.

Warning:

On the inside of the driver's side vehicle frame is a wiring harness that is held in place with plastic clips. This section of wiring harness must be moved aside by removing plastic clips from frame. This will allow the hitch parts to be positioned correctly on frame.

1. Place the two bed rails across the truck bed between the wheel wells. See Figure 1. Position the 5th wheel uprights on to the bed rails so that the tabs in the base of each upright will fit into the slots in the ends of the bed rails. Secure the uprights in place with the rail hitch pins and hair pins supplied with 5th wheel installation kit. Securely attach 5th wheel cross member to uprights.

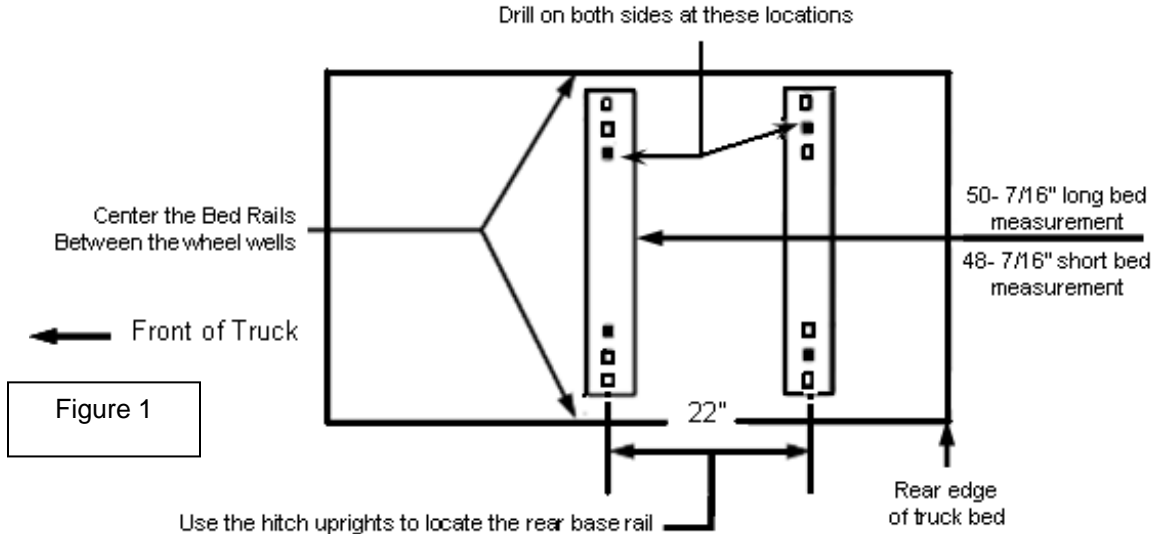

2. Position the bed rail assembly in truck bed as shown on Figure 1. Be sure bed rails are parallel by measuring diagonally as shown in Figure 2. Measurements should be less than 1/4" different.

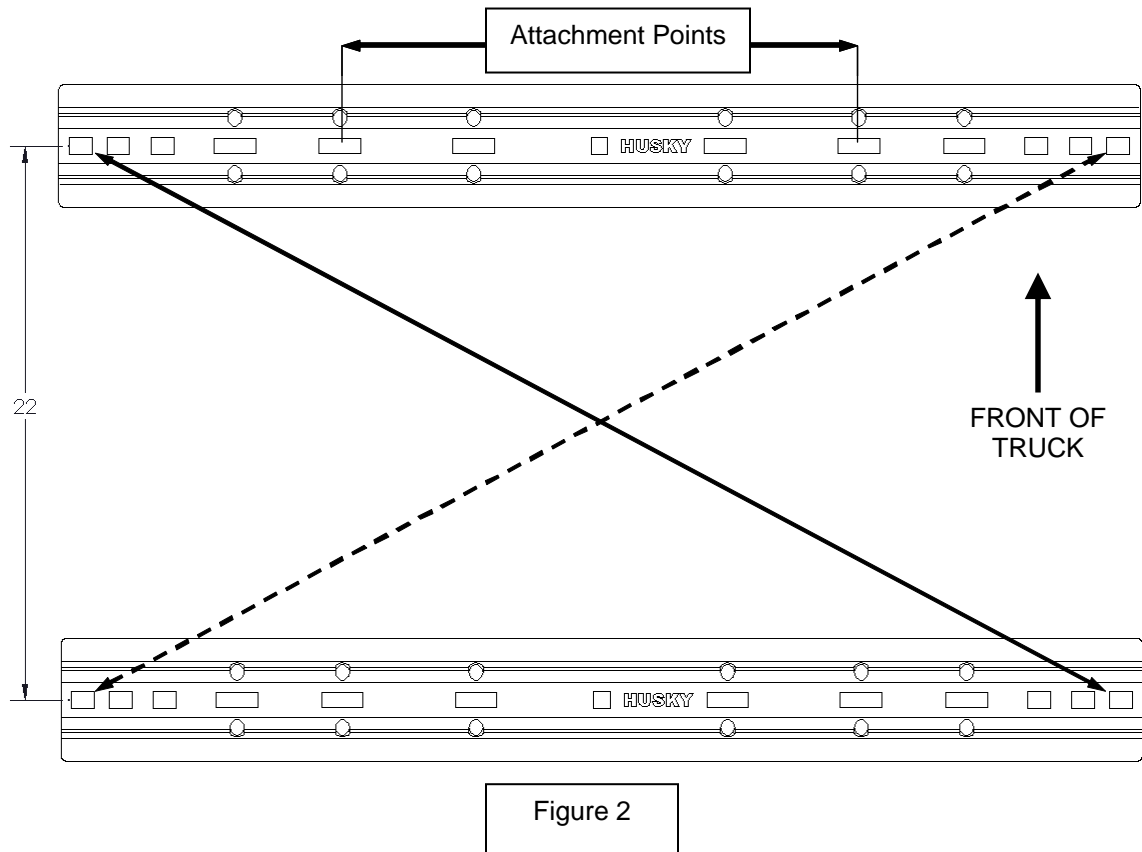

3. Mark two attachment points on the truck using the slots in the front base rail as indicated on Figure 2.

NOTE: Mark to the inner edge of the forward slots.

DO NOT mark rear bed rail points at this time. Check below the bed **before** drilling holes to see that all wiring, brake lines or other obstructions are moved out of the way and will not be contacted by drill. Drill 1/4" diameter pilot holes down through the bed and hat section at the previously marked points. Be certain that the holes are drilled in correct location. They must also be drilled through the under bed hat section. See Figure 3.

4. Position the left and right front outer brackets #1 and #3 against their respective truck frames so that the pin in each bracket aligns with the existing hole in the side of the vehicle frame. See Figure 4.

NOTE: On the 1500 series truck do **not** use existing hole if any. You will be required to drill a hole in the side of each truck frame. See Figure 3 for hole location information. Be sure the holes are placed exactly as shown and drilled to the correct diameter.

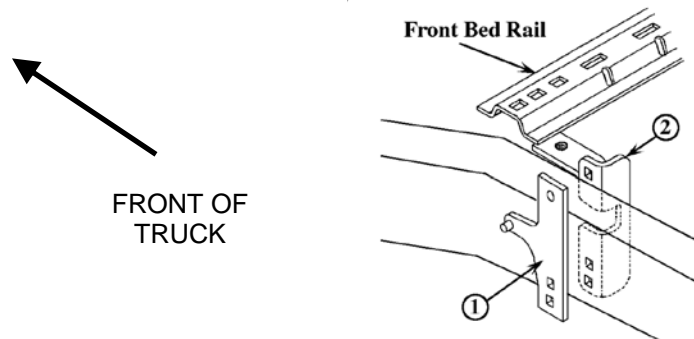

Figure 4

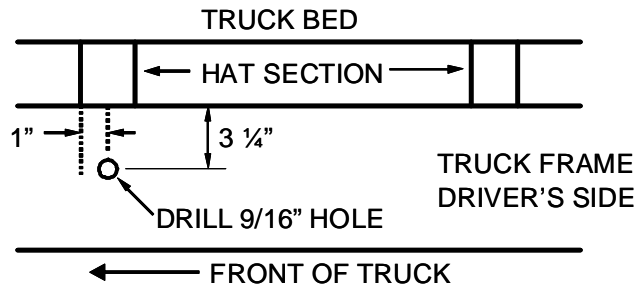

Figure 3

NOTE: On 2500HD and 3500HD series trucks there may be a wire hanger bracket bolted to the frame at a location which will not allow the front frame bracket to be installed. This wire bracket will have to be removed from the frame so that the frame bracket can be installed.

5. Bolt the left and right front outer brackets #1 and #3 to frame the inner brackets #2 and #4. Take care when positioning the left inner bracket #2 so that the slot in bracket fits over the steel brake line. See Figure 5. Use the carriage bolts (#15) at both bracket attachments. Slide bracket #2 rearward away from the gas tank so long bolt can be installed. Then slide bracket forward into position. Use the lower hole in each bracket for the 2500HD and 3500HD trucks and the upper hole in each bracket for the 1500 trucks. Bolts must be as close to bottom of truck frame as possible. The tab on the inner bracket should be against the bottom of the bed support hat section. The hole in the tab should be aligned with the previously drilled 1/4" pilot hole.

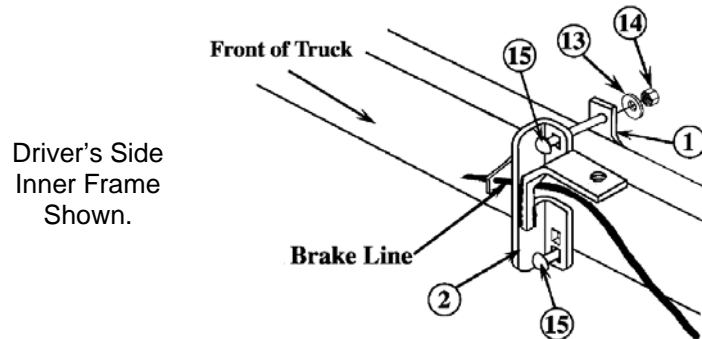
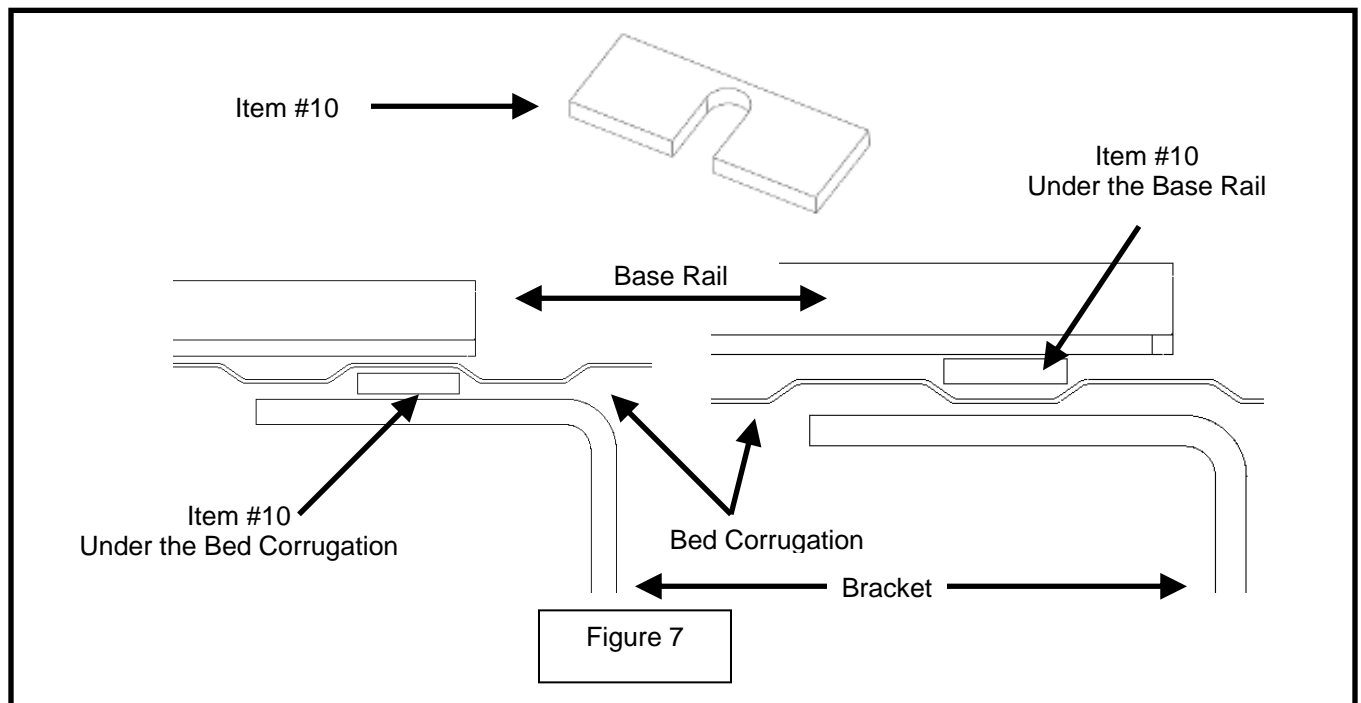
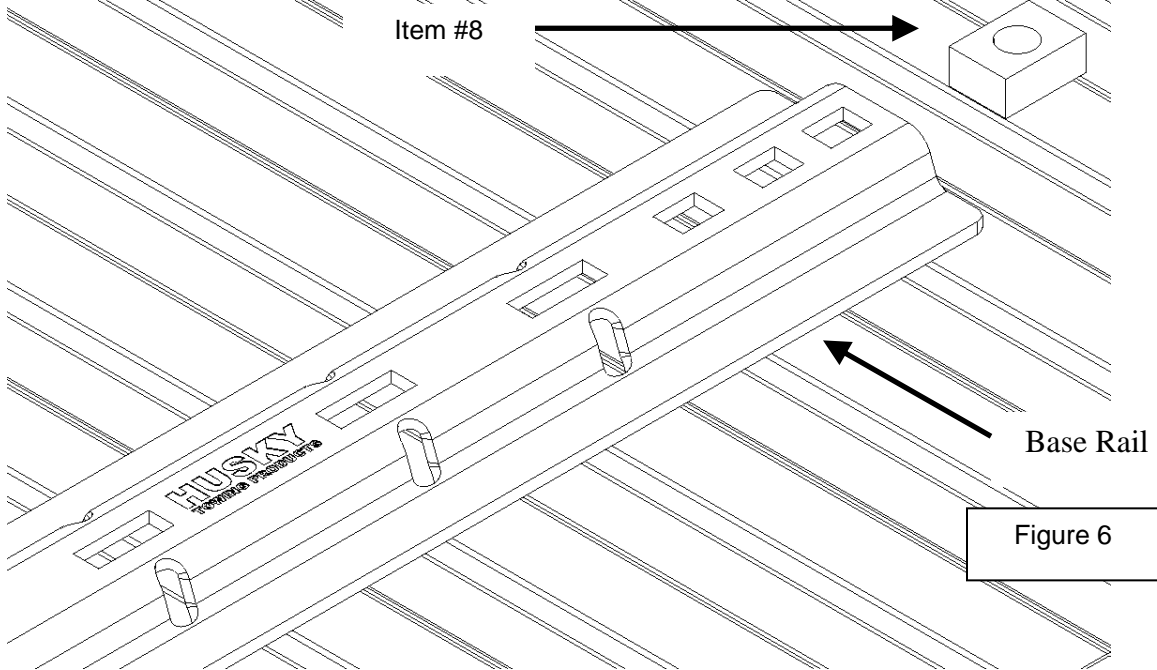

Figure 5

- Position the bed rails in the bed so that the inner square 5/8" hole in the front rail is lined up over the previously drilled pilot holes. Double check that the pilot holes line up with holes in bed rail and tab on frame bracket under the bed. Move bed rails away from pilot holes and drill a 3/4" hole down through truck bed at each of the previously drill pilot holes. The 3/4" hole will give some tolerance to get bolt down into the bracket hole. **Use caution when drilling so that drill does not make contact with the installed brackets or fuel tank under bed.**

NOTE: For alternative installation procedures refer to the last page of this document.

- Place a 3/4" thick spacer plate (#8) under ends of each bed rail, in line with the drilled holes, as shown in Figure 6. If the bed corrugation above the mounting bracket at the drilled hole is UP, leaving a space above the bracket, place a spacer plate (#10) in this location as shown in Figure 7. If the corrugation is DOWN, at this location, place a spacer plate (#10) in the bed, under the base rail as shown in Figure 7.



- Slide tube spacers (#9) into the forward bed support hat section from the open end in each wheel well.

NOTE: On some applications a small sheet metal flange may appear to obstruct placement of the spacer tube. This flange can be modified to gain access to the hat section. Make (2) 3/4" cuts in the truck bed flange near the hat section. Bend the cut section outward. Then insert the tube spacer. See Figure 8.

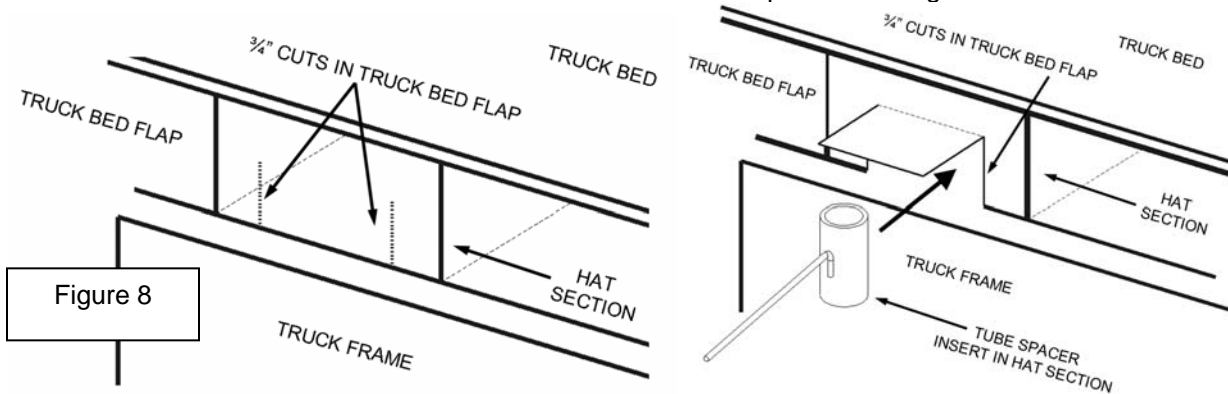

- On driver's side of the truck align the tube spacer with drilled hole and drop the 5/8" bolts (#17) with the flat washers (#18) and lock washer (#20) down through all parts and mounting brackets. Thread bolt into tapped plate on left front inner bracket, #2. Repeat procedure on the passenger side of the front bed rail using the same fasteners. See Figure 9. Tighten 5/8" bolts to 150 ft.- lbs. torque. Bend the cut section back to its original position and the installation will be complete. Paint or undercoat the cut areas to help prevent corrosion.

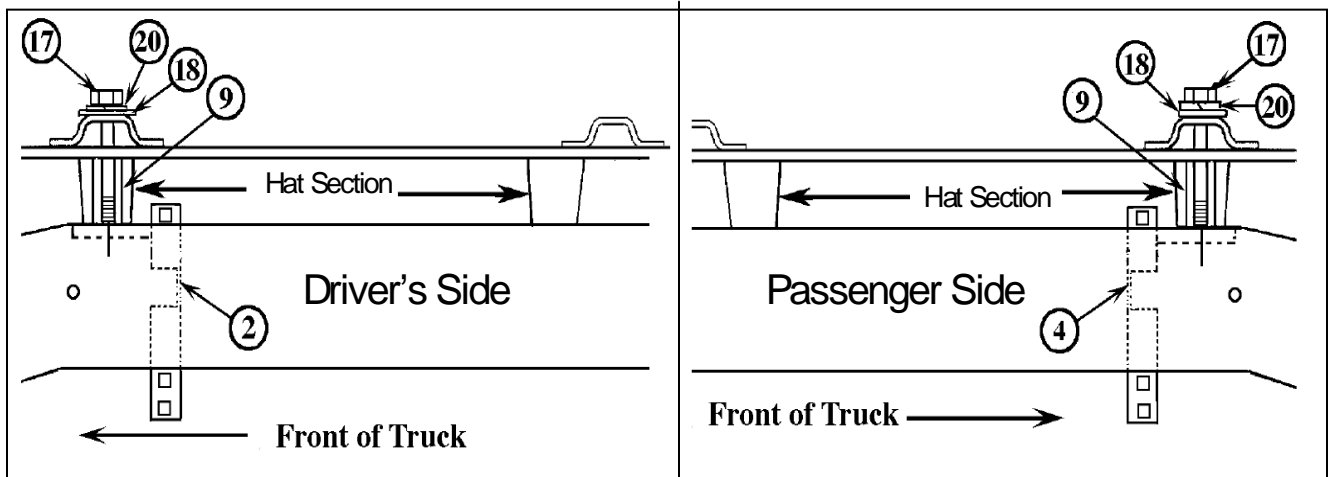
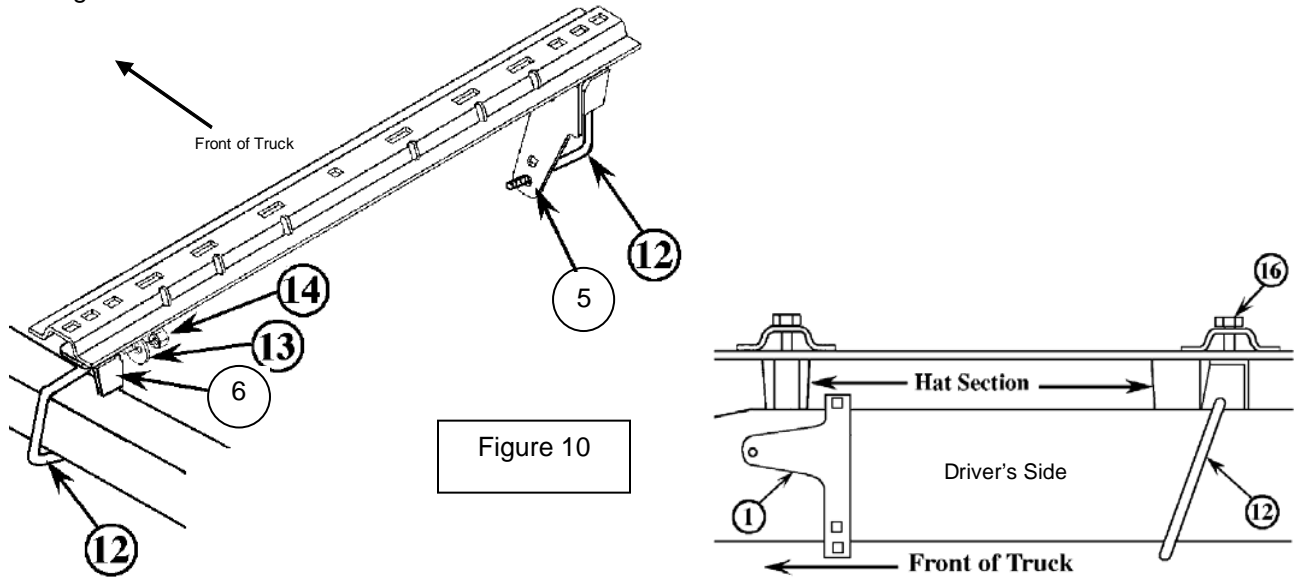

Figure 9

- Mark the rear hole locations using the rear bed rails as shown on Figure 1. Drill a 5/8" hole down through bed using the center 5/8" hole in each end of rear bed rail as a guide as shown in Figure 1.
- Place spacer plates under bed rails as described in Step 6. Place the short 5/8" bolts (#16) with wide flat washers (#18) down through bed rail, spacer plates and truck bed at drilled holes.

2500HD & 3500HD Applications:

- Place the left and right rear inner mounting brackets (#5 & #6) up in place against the inside surface of the vehicle frame, just behind the under bed hat section reinforcement. See Figure 10. The previously installed 5/8" bolts should go through the upper tab in each bracket. NOTE: The rubber tailpipe hanger may need to be moved away from the frame slightly so that the right bracket can be positioned correctly. Bolt the brackets loosely in place at these bolts with flat washers (#19), lock washers (#20), and hex nuts (#21).
- Secure the left and right inner mounting brackets in place with the longer U-bolts (#12) placed around truck frame as shown in Figure 10. Use the lower hole in each bracket for the 2500HD and 3500HD trucks. Bolt must be as close to bottom of truck frame as possible.
- Tighten all 1/2" bolts to 75 ft.-lbs. and all 5/8" bolts to 150 ft.-lbs.



NOTE: After the U-bolts are installed and torqued to specification, the lower leg of the U-bolts may need to be trimmed off to clear leaf springs or suspension parts.

- Check each base rail hitch pin for freedom of movement before tightening the 5/8" base rail bolts. Adjust the uprights, if necessary by placing a shim, (part # 30703; sold separately; 4 required) between the upright and cross member to obtain free movement. See Figure 11.

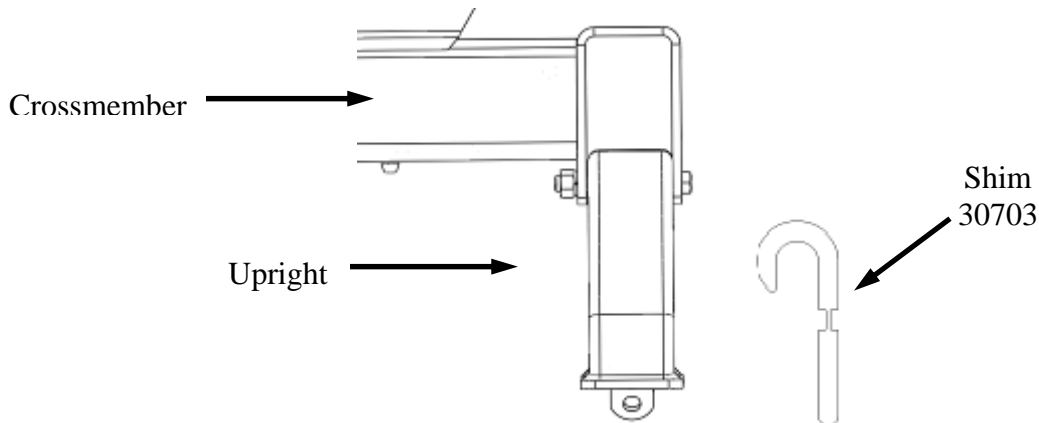
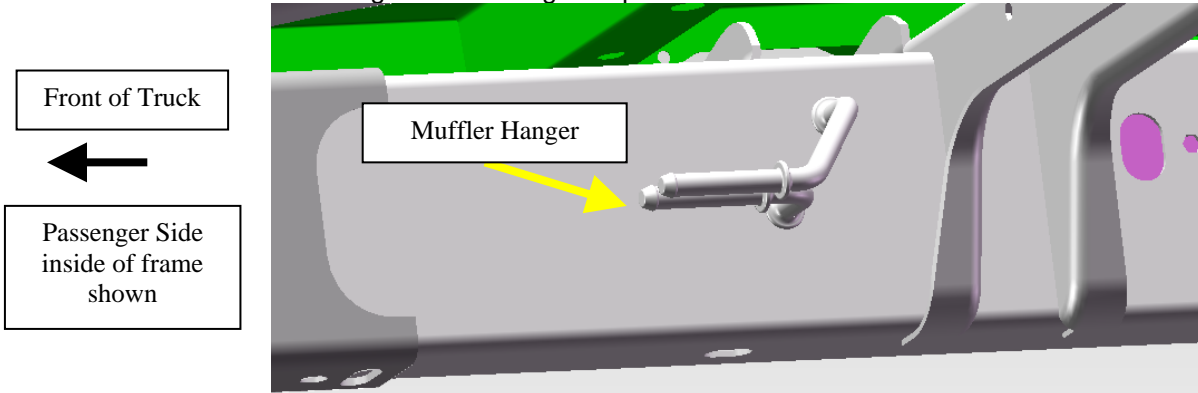

Figure 11

Alternative Installation Procedure for 2500HD & 3500HD Applications:

Some models may have difficulty installing the passenger side rear bracket (#5) due to the exhaust & muffler hanger & spare tire heat shield. An alternative method of installing this bracket is to loosen the passenger side bed bolts and temporarily raise the bed 1/4". This will allow the passenger side rear bracket (#5) to be installed without removing the exhaust from the muffler hanger or removing the spare tire heat shield.



12A) Loosen (DON'T REMOVE) the 4 passenger side bed bolts using a 13mm thin wall socket and 12" extension.

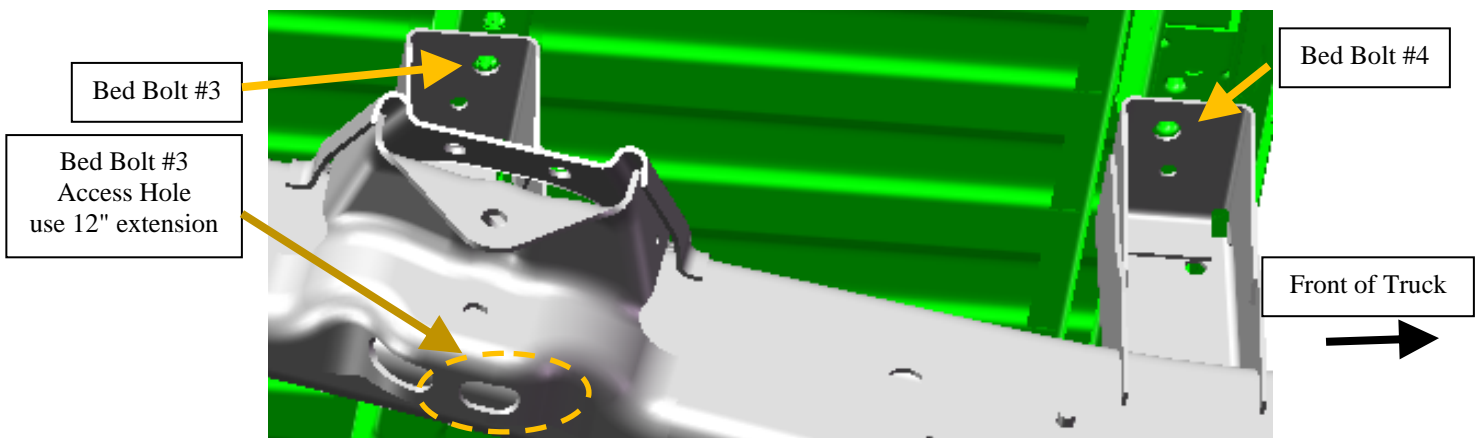
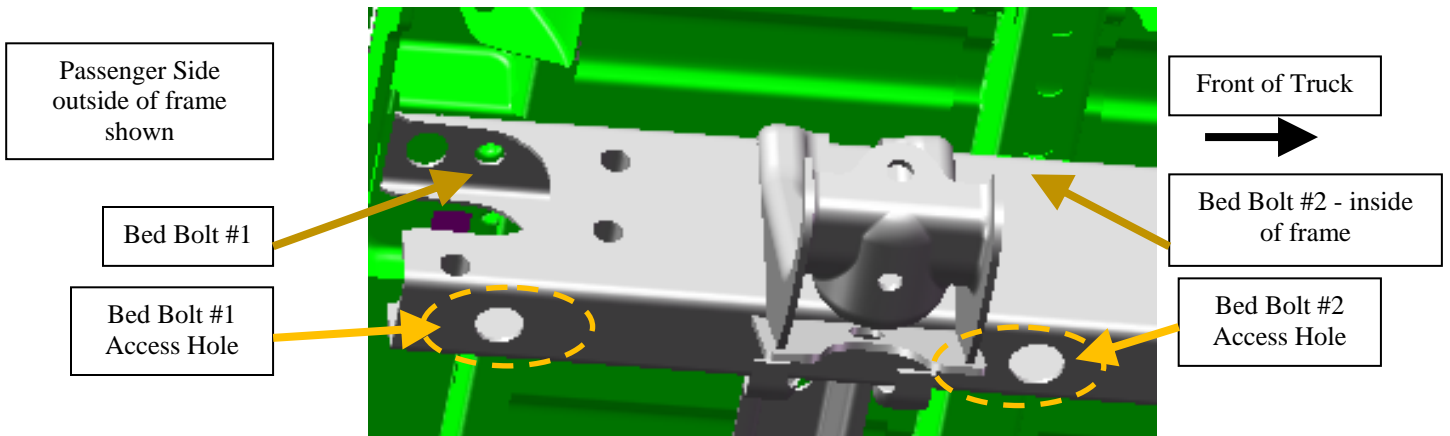
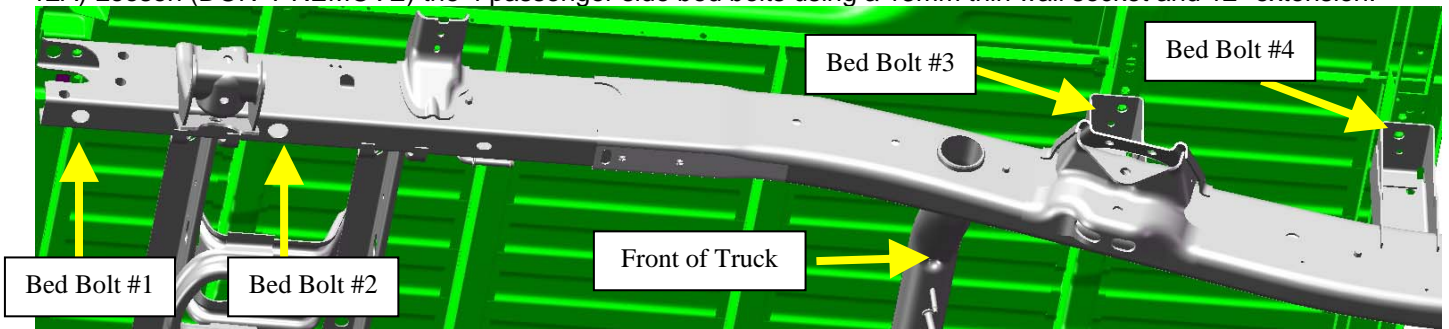

12B) Use pry bar to raise truck bed enough to temporarily insert spacer plate (#10) in between the truck frame and hat channel just above passenger side rear bracket (#5) location.

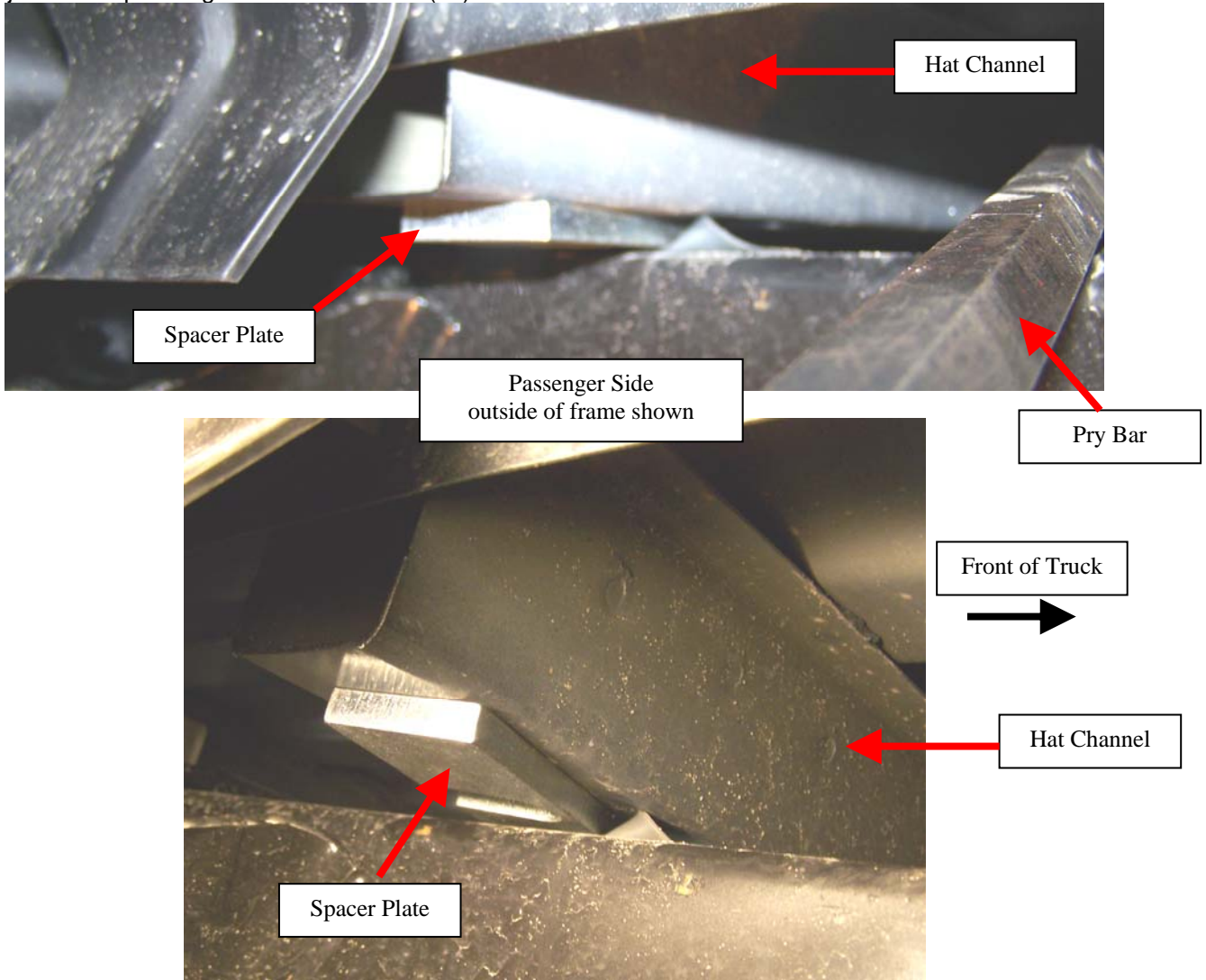

12C) Install passenger side rear bracket (#5) as shown in Figure 10. Remove the spacer plate. Retighten the passenger side bed bolts. Continue with Step 13 on page 6.

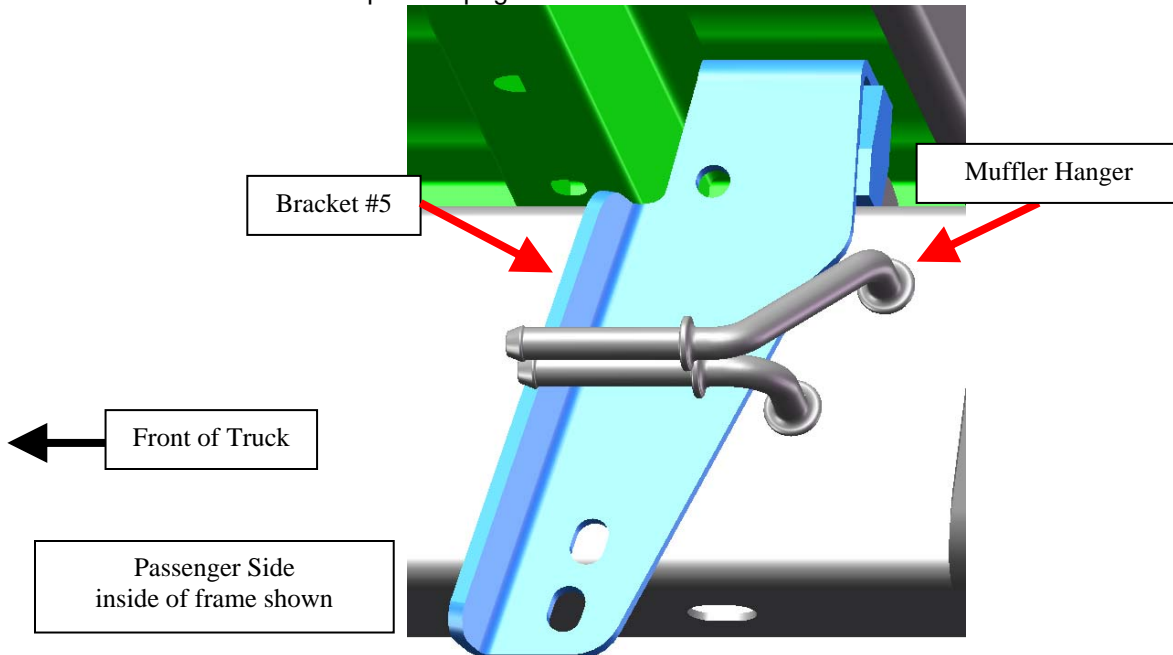

1500 Applications:

12. Place the left rear mounting bracket (#5) against the outside surface of the right frame and the right rear mounting bracket (#6) against the outside surface of the left frame with the mounting tabs positioned over the truck frame rails in line with the previously installed 5/8" bolts. See Figure 12 which shows the left frame. Bolt the brackets loosely in place at these bolts with flat washers (#19), lock washers (#20), and hex nuts (#21).

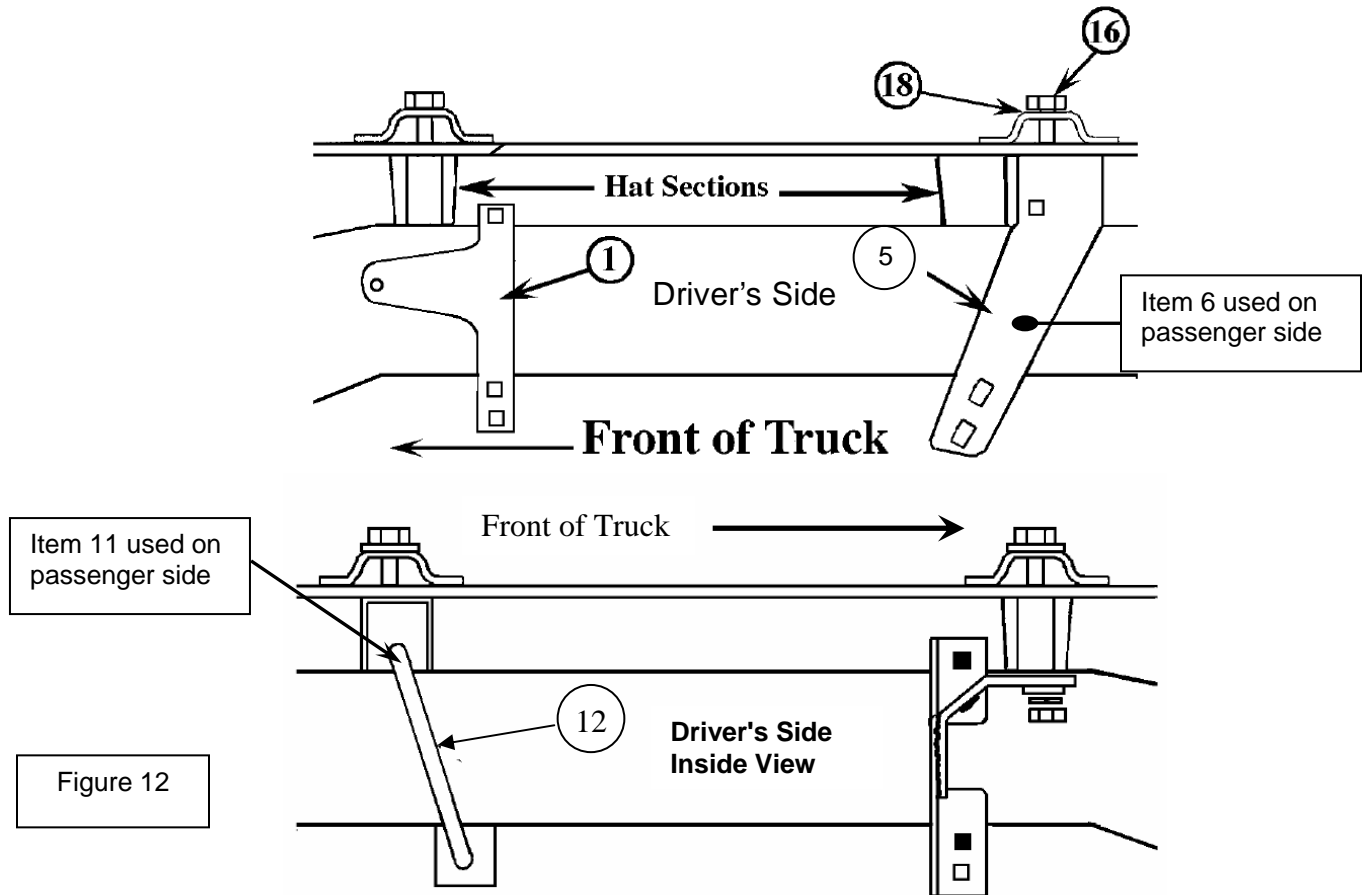

13. Secure the rear mounting bracket (#6) to the driver's side of the truck frame with one of the long U-Bolts (#12) and spacer bracket (#7) as shown in Figure 13.

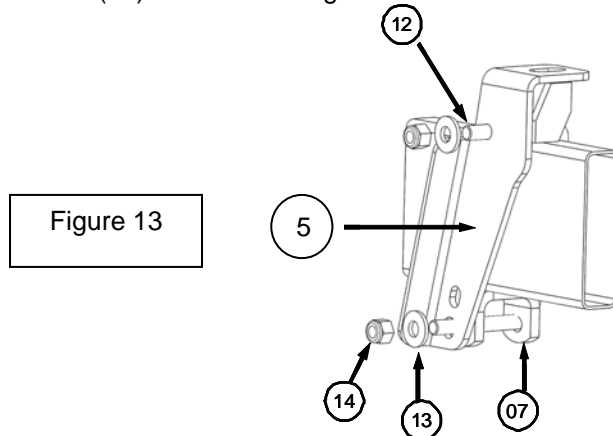

14. Secure the rear mounting bracket (#5) to the right truck frame with the short U-bolt (#11) as shown in Figure

Warning: After the U-bolts are installed and torqued to specification, the lower leg of the U-bolts may need to be trimmed off to clear leaf springs or suspension parts.

15. Tighten all 1/2" bolts to 75 ft.-lbs. torque and all 5/8" bolts to 150 ft.-lbs.

16. Check each base rail hitch pin for freedom of movement before tightening the 5/8" base rail bolts. Adjust the uprights, if necessary by placing a shim, (part # 30703; sold separately; 4 required) between the upright and cross member to obtain free movement. See Figure 14.

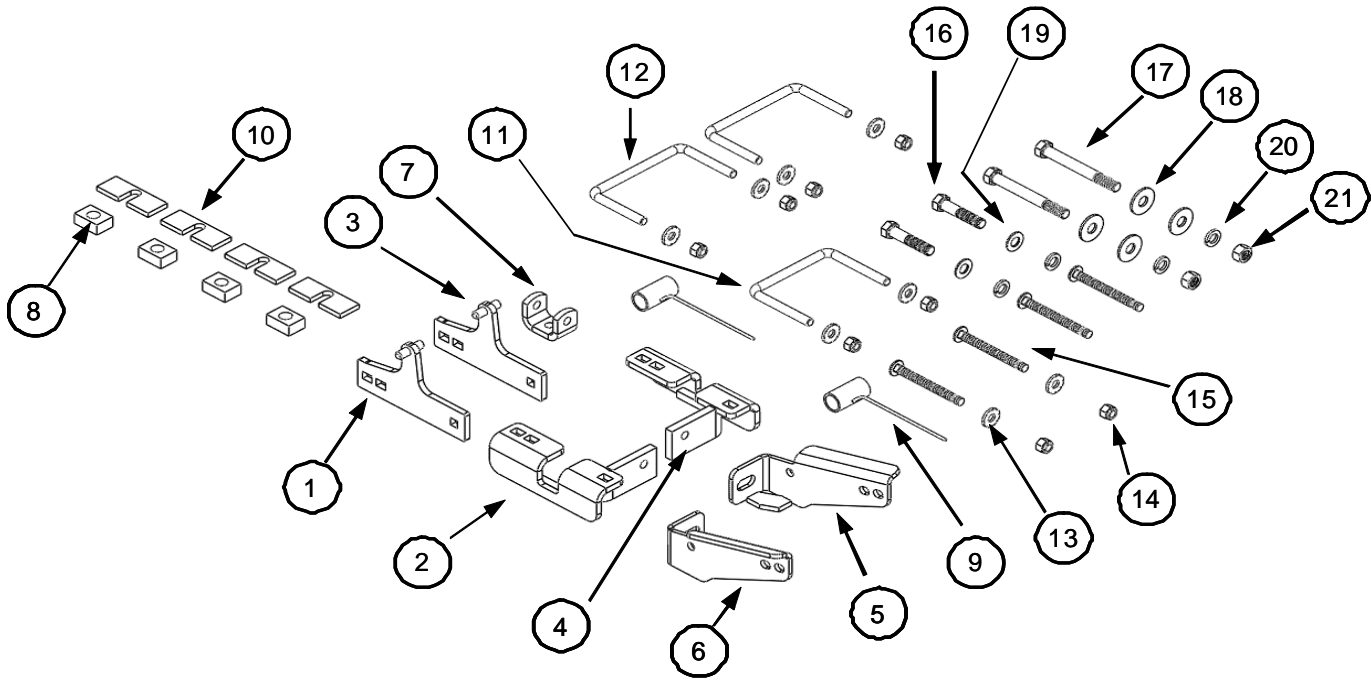
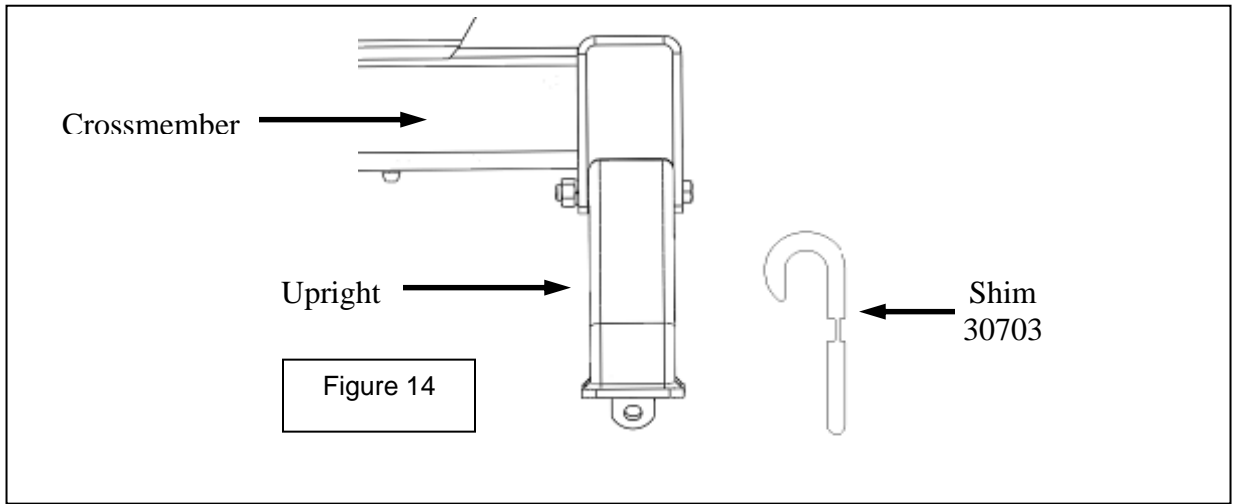

Torque Value Chart	
Bolt size	Torque Range (ft. - lbs)
1/2	75
9/16	110
5/8	150
3/4	260

Alternative Installation Procedure for 1500 Applications:

BE SURE TO ADVISE CUSTOMER ABOUT THE LARGE HOLES THAT WILL BE CUT INTO BED BEFORE BEGINNING THIS INSTALLATION.

1. Cut a 1-1/4" hole down through the bed at pilot hole location. This hole must only be cut through bed of truck, not through bottom of hat section under the bed.
2. Drill a 5/8" hole through bottom of the hat section under the bed at the previously drilled pilot hole.
3. Remove the wire handle from spacer tube #9. Drop the spacer tube down through the hole in bed so that it will rest on the under bed hat section in line with the previously drilled 5/8" diameter hole.
4. With the front base rail in place; drop one of the 5/8 X 5-1/2" hex bolts (#17) down through the base rail, tube spacer, and frame bracket tab. Bolt securely in place at this location.
5. Repeat procedure on other end of front base rail.
6. Tighten 5/8 bolts to 150 ft - lbs.
7. Continue with Step 10 in the main Instructions.

