

Quic'n Easy

RECEIVER HITCH

BY:



Operator's Manual

TO THE OWNER

UTP/DMI has built performance, features, reliability and long life into the Quic'n Easy™ receiver hitch. The Quic'n Easy™ receiver hitch is designed for today's lighter, fuel efficient pickup trucks. As truck weights have become lighter, tow loads have become heavier. United Truck Parts urges you to read and understand this manual. It is your responsibility to operate and service this product properly to fully realize all the built-in benefits and features.

This bumper complies with all safety specifications and requirements for trailering systems.



WARNING: FAILURE TO FOLLOW APPROPRIATE SAFETY PRECAUTIONS, SUCH AS THOSE OUTLINED HEREIN, MAY RESULT IN ACCELERATED WEAR OR THE CREATION OF HAZARDOUS CONDITIONS WHICH COULD CAUSE SERIOUS INJURY OR FATALITY.

HITCH SAFETY DIAGRAM



CAUTION:

Failure to follow safety recommendations on this page may result in personal injury.

The Towbar Pin Lock (Top) handle moves with the hitch cushion action. To prevent accidental disengagement of the towbar pin:

- Never block the motion of the towbar pin-lock handle
- Do not tow a trailer if the pin lock (top) or swing lock (bottom) handles are damaged or bent from the original shape shown.

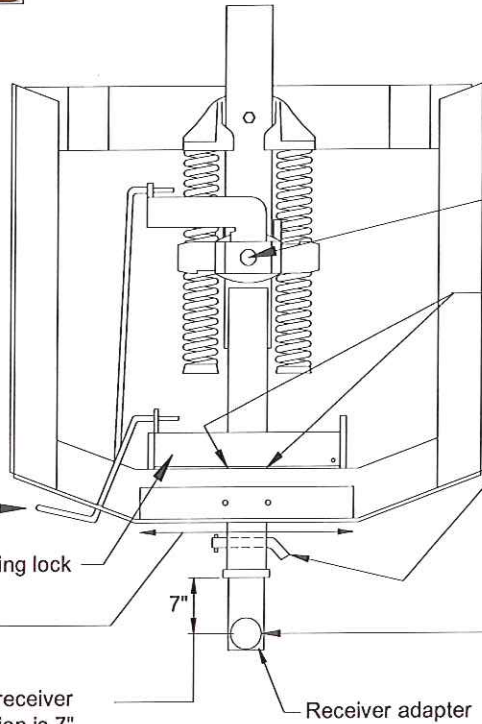

Be sure the towbar pin is engaged before towing.

Be sure the receiver tube swing lock is seated down around the receiver tube before towing.

Check $\frac{5}{8}$ " receiver pin and $\frac{3}{16}$ " klik pin for proper installation before towing.

When installing hitch ball:

- Always use the nut and lock washer provided with the hitch ball.
- Tighten nut to manufacturer's torque instructions.
- Check torque at 100 miles after initial assembly and every 250 miles thereafter.

Keep fingers out of the receiver tube slot area.

Maximum recommended receiver adapter overhand dimension is 7" from the face of the receiver tube to the center of the hitch ball.

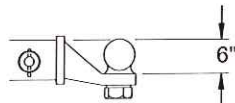

Maximum recommended receiver adapter vertical offset (up or down) is 6" from top of the receiver adapter to the hitch ball mounting surface.

1. Do not exceed truck manufacturer's towing specifications.
2. Comply with all trailering regulations such as safety chains, lights, brakes, weight distribution, etc.
3. Check all mounting bolts periodically. Torque per specifications in manual.
4. Do not modify receiver hitch or mounting brackets
5. Receiver hitch should only be used by persons familiar with its function, operators manual, and safety regulations.
6. Never stand between trailer and towing vehicle while vehicle is in motion.
7. Keep fingers out of receiver tube slot area and hole in towbar when moving or stowing receiver tube.
8. Be sure that the lock pin is engaged before transporting.
9. On trailers with clevis type hitches use the largest diameter hitch pin possible with a retaining device to lock pin in place.



CAUTION:

- BE SURE DRAW BAR LOCK PIN AND SIDE-SWING LOCK ARE ENGAGED BEFORE TRANSPORTING
- NEVER STAND BETWEEN TRAILER AND TOWING VEHICLE WHILE VEHICLE IS IN MOTION

HOOK-UP PROCEDURE

1. Attach and secure receiver adapter draw bar to receiver tube in Quic'n Easy with receiver pin and 3/16" klik pin.
2. Install hitch ball to receiver adapter draw bar and torque to manufacturer specification.
3. Maneuver truck to locate hitch ball close to trailer coupler. Turn off engine and set parking brake.
4. Attach and secure coupler on trailer hitch to hitch ball.
 - Pull handle on left to swing receiver side to side
 - Pull handle on right to extend receiver rearward or forward
5. Trailers without jack:
 - Slowly back up to engage drawbar lock pin.
 - Slowly pull forward to center receiver tube.Trailers with jack:
 - Leave tongue supported by jack.
 - Slowly back up to engage drawbar lock pin.
 - Raise jack to transport position.
 - Slowly pull forward to center receiver tube.



CAUTION: KEEP FINGERS OUT OF RECEIVER TUBE SLOT AREA AND HOLE IN TOWBAR WHEN MOVING OR STOWING.

MAINTENANCE

Receiver hitch maintenance must be conducted periodically to look for worn, missing, broken, or loose parts. These parts affect the operation, function, and safety of the Quic'n Easy receiver hitch. They could result in unsatisfactory performance, trailering (swaying of trailer or jack-knifing of truck), and possible dangerous or fatal conditions.

1. Periodically check wear pads to make sure that the receiver tube slides on the wear pads. There should be 1/16 of an inch between the top of receiver and bottom of top wear plate. Add shims under wear pads if required.
2. Keep all bolts tight. Check all connections periodically.
3. Use only authorized repair parts obtainable from your local dealer.
4. TORQUE ALL BOLTS TO THE FOLLOWING SPECIFICATION:
 - 7/16 dia. Gd. 5 to...55 ft-lbs
 - 1/2" dia. Gd. 5 to...85 ft-lbs
 - 9/16 dia. Gd. 5 to...125 ft-lbs
 - 5/8" dia. Gd. 5 to...170 ft-lbs

RECEIVER TUBE ADJUSTMENT

Your new Quic'n Easy™ receiver hitch has a floating spring mount casting feature, and when the casting is properly adjusted the towbar will telescope more easily. After the bumper hitch is installed on the truck, please do the following:

1. Check to see if the top or bottom surface of the towbar (ref. #3) is contacting the spring mount casting (ref. #16).
2. The underside of the towbar should contact the spring mount casting as shown below. Adjust this by tightening nut (Ref. #56) until casting moves up and touches towbar.

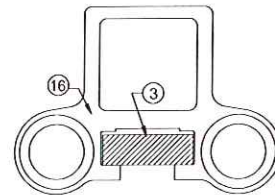

IMPORTANT: If nut is too tight, towbar will not swing from left to right. Be sure towbar swings freely.

DETERMINE THE TOWING WEIGHTS

The most important factors in choosing the correct towing equipment is the gross trailer weight (GTW) and the tongue weight (TW).

FOR THE TRAILER: Gross trailer weight is the weight of the trailer completely loaded. To determine actual GTW, the trailer should be placed on a vehicle scale. To determine the approximate GTW, refer to the registration tag attached to the trailer.

TONGUE WEIGHT (TW): The downward force exerted on the hitch ball by the trailer coupler is the tongue weight. To determine TW, weigh the trailer tongue with loaded trailer and trailer tongue raised to normal towing height.

FOR THE TOW VEHICLE: The vehicle's maximum towing capacity is determined by the manufacturer. This information is found in the truck owner's manual. This rating is based on many factors including: engine options, transmission options, differential gear ratios and other optional equipment. **Determine the maximum towing capacity for the particular truck that the hitch is mounted on.**

SELECT THE PROPER ACCESSORIES

The Quic'n Easy receiver hitch exceeds SAE Class IV standards. However, the entire towing system capacity is limited to the **lowest capacity** of any component within the towing system. For example, while the Quic'n Easy receiver hitch is rated for 18,000 lbs GTW and 1,800 lbs TW, if the ball is rated to 6,000 lbs capacity, the towing system capacity is 6,000 lbs.

To determine the towing system capacity, fill in the information on the chart below. Remember, the **lowest rating** on the chart will determine the **maximum towing capacity of the towing system**.

ITEM	MAXIMUM TOWING CAPACITIES	
	TRAILER TONGUE WEIGHT (TW)	GROSS TRAILER WEIGHT (GTW)
Vehicle Rated Towing Capacity (from Vehicle Owner's Manual)		
Quic'n Easy Receiver Hitch	1,800 lbs	18,000 lbs
Receiver Adapter Draw Bar (stamped on the adapter or from owner's manual)		
Hitch Ball (stamped on ball)		
Coupler on Trailer (stamped on the adapter or from owner's manual)		
Safety Chain (manufacturer's rating)		
LOWEST LISTED RATINGS		
TRAILER TOWING WEIGHT		
 WARNING:	Overloading towing sytem components could result in serious injury or death. Do not attempt to tow trailer if trailer towing weight or tongue weight exceeds lowest listed ratings . Upgrade the components as necessary to riase the capacity of the towing system to match the trailer being towed.	

TRAILER TOWING TIPS

With a trailer in tow, you are operating a vehicle combination that is longer, heavier, and sometimes wider and taller than you are used to. You will have to make some compensating adjustments in your driving practices.

Slow Down. Moderate to slow speeds put less strain on your vehicle and trailer.

Allow Extra Time and Space. You will need both with passing and stopping, especially if your trailer has no brakes.

Check Rear View Mirrors. Doing this frequently will let you know that your trailer is riding properly.

Swing Wider. You need to make wider swings at curves and corners because your trailer's wheels are closer to the inside of a turn than the wheels of your vehicle.

Pass with Extra Care. It takes more time and distance to get around a slower vehicle and return to the right lane when you have a trailer in tow.

Watch the Wind. To avoid swaying, be prepared for sudden changes in air pressure and wind buffeting when larger vehicles pass from either direction. Slow down a bit and keep a firm hold on your steering wheel. Aim straight down your lane.

Conserve Fuel. You will go farther on a tank of gas at moderate speeds. Higher speeds increase wind resistance against the trailer and reduce your gas mileage significantly.

Avoid Sudden Stops and Starts. This can cause skidding, sliding, or jackknifing, even if your trailer has brakes. Avoid quick stops while turning. Smooth, gradual starts and stops will improve your gas mileage.

Signal Your Intentions. Let surrounding vehicles know what you intend to do well before you stop, turn, change lanes, or pass.

Shift to a Lower Gear. A lower gear will help ease the load on a transmission and engine when going over steep hills, sand, gravel, or dirt roads. If your tow vehicle has an "overdrive" gear, shifting out of overdrive to a lower gear may help improve your gas mileage.

Always be Courteous. Make it as easy as possible for faster-moving vehicles to pass you. Keep to the right of the road and prepare to slow down if passing vehicles need extra time to return to their proper lane.

Do not Tailgate. Allow at least one car and trailer length between you and the vehicle in front for each 10 mph on your speedometer.

If a Problem Occurs. Do not panic. Stay cool. For example, if you experience a sudden bumping or fish-tailing, it may indicate a flat tire. Do not jam on the brakes or mash the accelerator in an attempt to drive out of it. Instead, come to a stop slowly as you keep driving in as straight a line as possible. If conditions permit, coast to a very slow speed and try to avoid braking, expect when your wheels are straight and your trailer and tow vehicle are in line with each other.

If your trailer begins to fishtail as you accelerate to highway speed, back off the accelerator. This should stop the fish-tailing. If it begins again as you increase speed, stop and check your load. It may not be distributed evenly from side to side, or it is too far back to put a sufficient tongue weight on the hitch ball. It is recommended that 10% of the trailer weight be on the hitch. Redistribute the load as necessary before continuing.

Quic 'n Easy Assembly: 47070007

NOTE: SHIM TOP WEAR BLOCK (ITEM 46) AS REQUIRED SO THAT DRAW BAR WELDMENT (ITEM 42) CAN SWING AND EXTEND FREELY WITH 1/32" MAX CLEARANCE AT WEAR BLOCK (ITEM 44).

ITEM 42 SHOWN WITHOUT REINFORCEMENT FLANGE

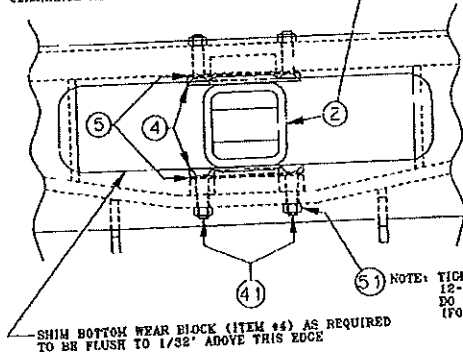

NOTE: TIGHTEN 6/18" NUT TO 12-15 FT-LBS DO NOT OVER TORQUE (FOUR PLACES)

SHIM BOTTOM WEAR BLOCK (ITEM 44) AS REQUIRED TO BE FLUSH TO 1/32" ABOVE THIS EDGE

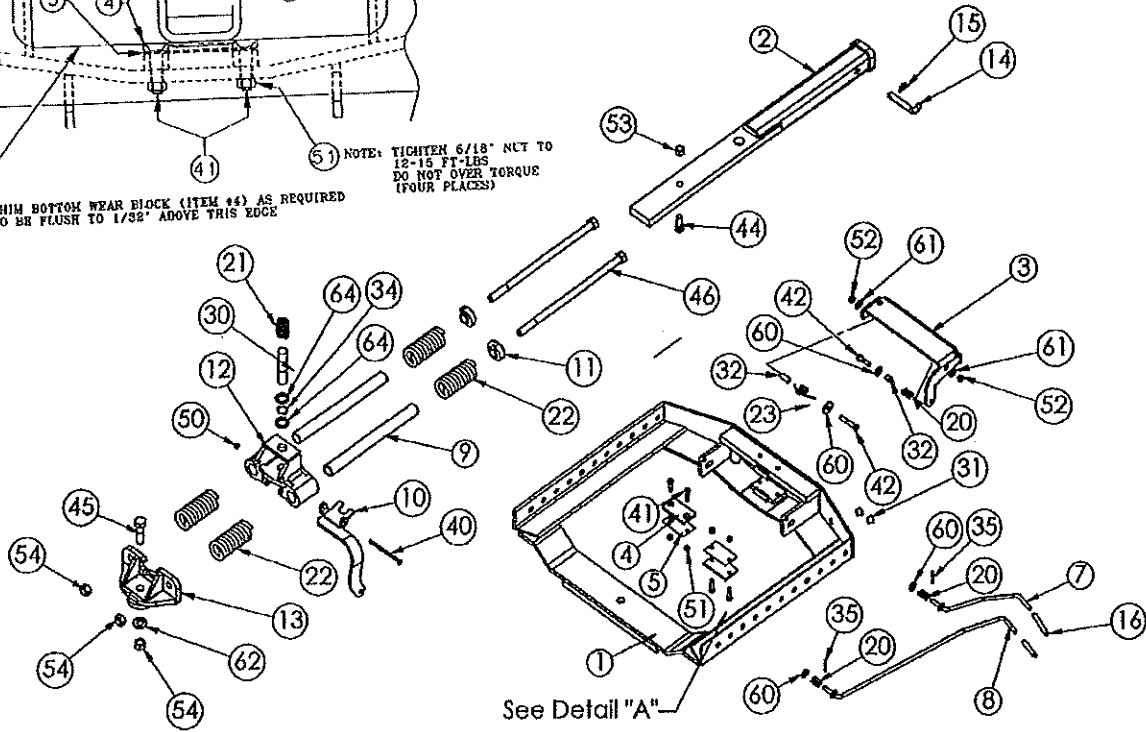

REF. NO.	PART NO.	QTY	DESCRIPTION	REF. NO.	PART NO.	QTY	DESCRIPTION
-	47090001	-	Quic 'n Easy Frame Assembly	30	47077250	1	Pin, Draw Bar Lock
1	47070007F	1	QE Frame Weldment	31	30003300	2	Grommet, Black Plastic Snap-In
2	47077460	1	Drawbar QE	32	44003802	2	Pivot Bushing, 1-1/8" Long
3	47077640DL1	1	Lock, Slide Swing QE/QCC	34	14610100	1	Snap Ring, Draw Bar Pin
4	47077425	2	Wear Block QE	35	14700502	2	5/32" x 1-1/2" Cotter Pin
5	47077426	2	Shim .020" QE/QCC	40	16004184	2	1/4"-20 x 4-1/2" NC Hex Bolt
7	47077485	1	Handle, Stop Lock QE	41	16900000	4	5/16"x1-1/2" NC FHMS
8	47077480	1	Handle, Pin Lever QE	42	16006095	2	3/8"-16 x 2-1/4" NC Hex Bolt
9	47070010	2	Pipe fabricated	44	16010075	1	5/8"-11 x 1-1/2" NC Hex Bolt
10	47077470	1	Lever	45	16912115	1	3/4"-10 x 2-3/4" GRD 8 HHCS
11	20092160	2	Spring Retainer Casting	46	16912645	2	3/4" x 16" NC Hex Bolt
12	20092161	1	Spring Mount Casting	50	14110401	1	1/4" NC Hex Nyloc Locknut
13	20092170	1	Towbar Mounting Casting	51	14010501	4	5/16" NC Hex Nyloc Locknut
14	47077915	1	Receiver Pin 5/8" Dia.	52	14110601	2	3/8" NC Hex Nyloc Locknut
15	14710610	1	3/16" Dia. Klik Pin	53	14111001	1	5/8" NC Hex Nyloc Locknut
16	30003400	2	Plastic handle grip .375X3 red	54	14111201	3	3/4" NC Hex Nyloc Locknut
20	24108100	3	Compression Spring, Handle	60	17006001	4	3/8" Washer
21	24111201	1	Compression Spring, Lock Pin	61	17006001	2	3/8" Washer
22	24140610	4	Compression Spring, Cushion	62	17112000	1	3/4" SAE ZP Flat Washer
23	24512512	1	Torsion Spring, Slide Lock	64	17616011	2	1" Machine bushing Washer, 10 ga.

Appendix 5

LIMITED LIFETIME WARRANTY

This limited warranty (the "Warranty") is made and effective date of Company's invoice to Dealer.

Between: DEALER/DISTRIBUTOR (The "Dealer"), the ORIGINAL PURCHASER of each new UTP/DMI product as listed in Application Guide (**Appendix 5**)

And: UNITED TRUCK PARTS LLC (The "Company"), organized and existing under the laws of Indiana, with its head office located at 59 North Oak Street, Bluffton Indiana.

WARRANTY

The Company warrants to the Dealer and to the Dealer's original customer that the product will be free of defects in material and workmanship for the following periods:

WELDED STRUCTURAL MEMBERS Lifetime
ALL MOUNTING KITS, BUMPERS, AND COMPONENTS 1 year

EXCLUSIONS

This warranty does not cover wear parts.

This warranty covers only defective material or workmanship. It does not cover normal wear, maintenance, rust on the back side of the bumper, or repair resulting from accident, improper maintenance, improper use, or alteration of the product. Products improperly installed or installed using anything other than official Company mounting brackets and/or hardware are not covered by this warranty. The cost of normal maintenance, service, and repair items shall not be paid by the Company.

LIMITS OF LIABILITY

Under this warranty the Company shall at its option either repair or replace free of charge any defective part or parts. The part or parts must be returned to the Company within thirty (30) days from the date of failure, through the Dealer from whom the product was purchased. Transportation charges are prepaid by the Dealer. The only remedies are those which are outlined herein. The Company is not liable for consequential or incidental damages including, but not limited to, loss of crops, livestock, loss because of delay in harvesting, vacation, business, or any expense or loss incurred to labor, supplies, substitute machinery, or rental.

This warranty is subject to any existing conditions of supply which affect the Company's ability to obtain materials or manufacture replacement parts.

Company reserves the right to make improvements in design or changes in specification at any time without incurring any obligation to owners of products previously sold.

This warranty and its exclusions, limitations, and reservations may not be altered, modified, or enlarged by Dealer.

THE FOREGOING WARRANTY IS IN LIEU OF AND EXCLUDES ALL OTHER WARRANTIES, WHETHER EXPRESSED OR IMPLIED, BY OPERATION OF LAW OR OTHERWISE, INCLUDING THE IMPLIED WARRANTIES OF MERCHANTABILITY AND FITNESS FOR ANY PARTICULAR PURPOSE. BY INSTALLING OR USING THIS PRODUCT, THE USER ACCEPTS ALL TERMS DESCRIBED HEREIN.

10/31/2013

Almeo Steel Products Corp
dba United Truck Parts
59 North Oak Street Ext
Bluffton, IN 46714