



INSTALLATION INSTRUCTIONS

Electric/Hydraulic Actuator Adapter

For K58-036-00 and K58-036-01

This kit is designed for some cases where enhanced trailer detection is required involving tow vehicle OEM built-in brake controllers and the use of Dexter DX Series or Dexter BrakeRite® Electric/Hydraulic (E/H) actuators. This should not be used with any other E/H actuator manufacturer, trailers with electric brakes or any brake controllers not made specifically for E/H actuators.

Please see your tow vehicle manufacturer owner's manual before proceeding.

The tow vehicle OEM built-in brake controllers will not output voltage to the trailer brakes unless the dashboard says "Trailer Connected". For this reason, this compatibility adapter has been developed and should be used on a case by case basis.

Additionally, if the truck manufacturer dashboard indicates an issue such as "Not Connected or Check trailer wiring" after the trailer has been connected it is the responsibility of the driver NOT to pull the trailer when there are no working trailer brakes. This could also indicate a trailer wiring issue and should be investigated and corrected right away.

This adapter does not guarantee to solve all brake controller compatibility issues in the marketplace. Dexter does not have design control when manufacturers make design changes to brake controllers or when new model year changes are released.

Adapter Wiring Instructions:

Please use the instructions below in combination with the wiring diagrams to properly install.

K58-036-00:

1. The adapter should be mounted in a secure position to prevent movement during travel. It should be located so that wire tension will not affect the wiring connections.
2. Locate the brake signal wire (blue) and battery ground wire (white) just outside the E/H actuator. Cut and remove approximately .375" of wire coating from each end of the cut wire.
3. Reconnect the brake controller input wire (blue) and battery ground wire (white) with the corresponding color adapter wire using the supplied butt splice connectors (see below picture).

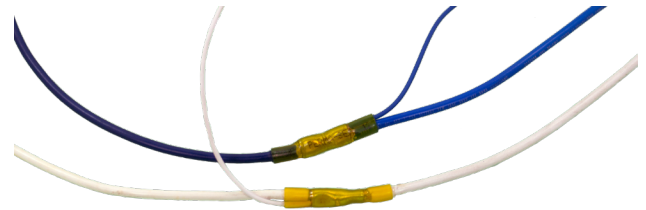

4. After the wires are crimped inside the butt splice connectors, they should be heat shrunk to protect the connections.

K58-036-01:

1. The adapter should be mounted in a secure position to prevent movement during travel. It should be located so that wire tension will not affect the wiring connections.
2. Locate the three wire plugs with the corresponding power (black), brake signal (blue) and battery ground (white) wires.
3. Disconnect plug and reconnect brake adapter 058-036-01 in between existing connections, essentially "teeing" the adapter in between the existing connectors.
4. Check the connections to verify they are secure.

K58-036-00 Wiring Diagram for DX Series Actuators:

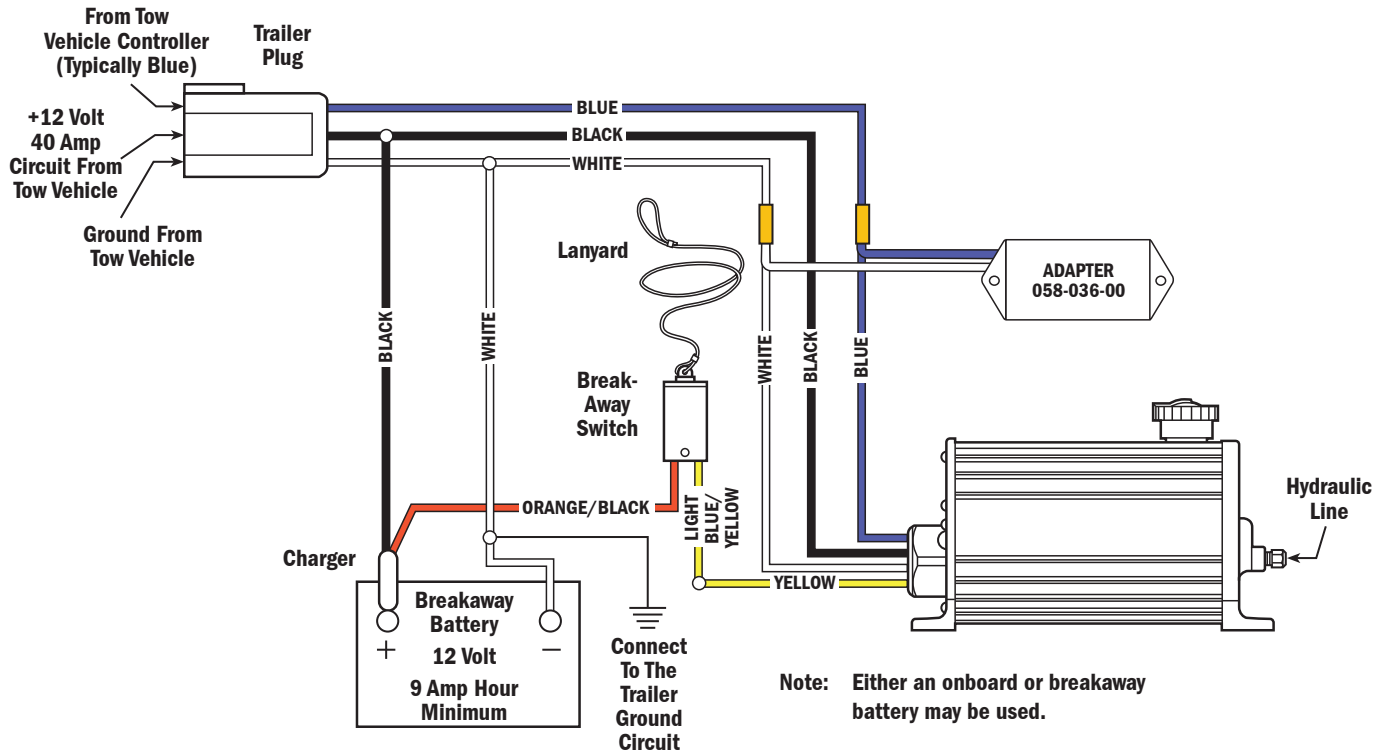

K58-036-00 Wiring Diagram for BrakeRite EHB Actuators:

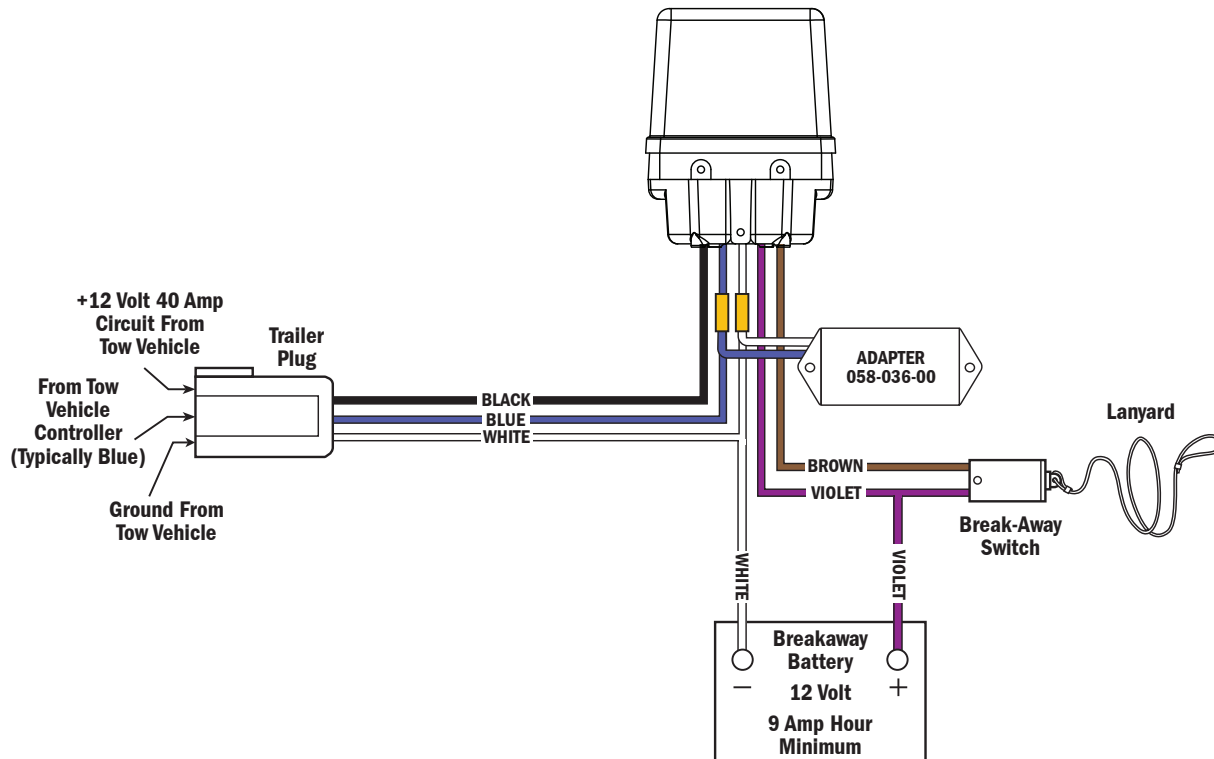

K58-036-01 Wiring Diagram for BrakeRite Plug and Play Actuators:

Weather-pack connectors are connected in-line to the existing BrakeRite harness near the actuator.

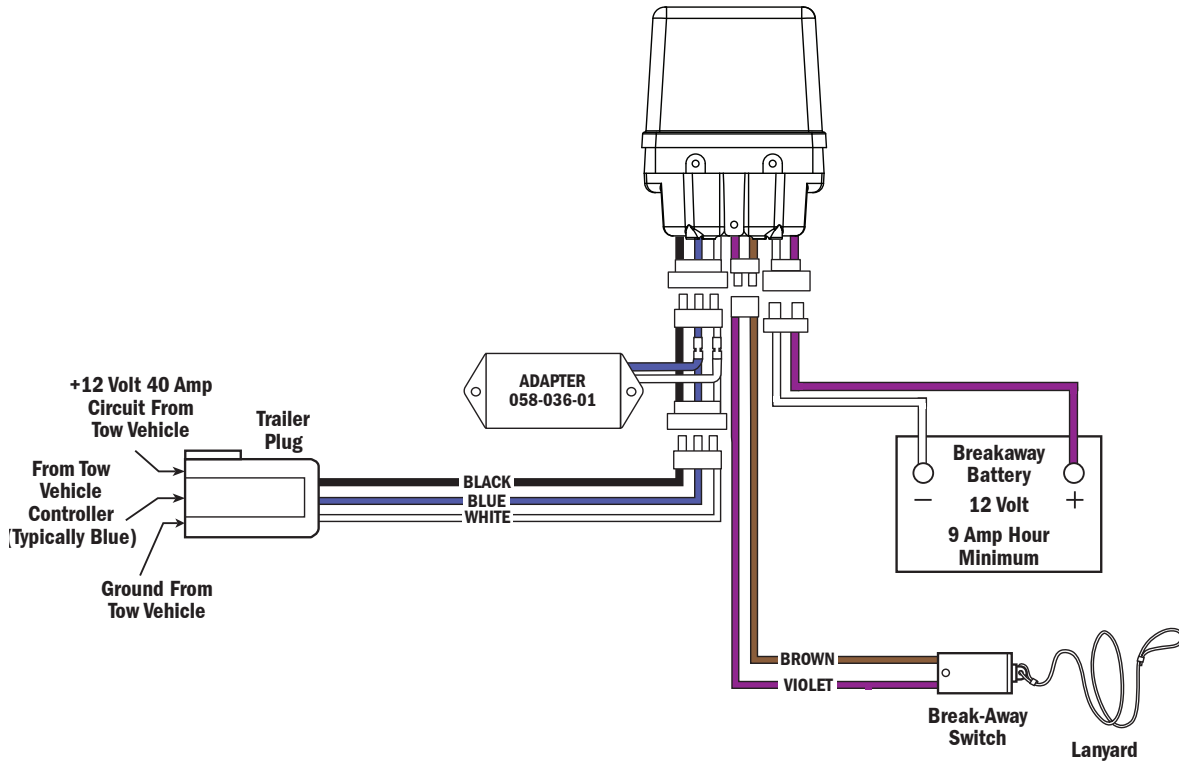

K58-036-01 Wiring Diagram for BrakeRite SD Actuators:

Weather-pack connectors are connected in-line to the existing BrakeRite harness near the actuator.

