

ROCK TAMERS[®]

MUDFLAP SYSTEM

00108/00110

INSTRUCTION MANUAL



Removable and Adjustable Mudflap System



IMPORTANT!

Please Read this Instruction ***Booklet*** prior to ***assembly*** of your Rock Tamer Kit.

IMPORTANT!

Exhaust Systems

Note: Any modifications to the factory installed exhaust system may void your manufacturer's warranty.

Car Washes

You must remove mudflap system before entering any drive-through car wash.

CAUTION

Consumer assumes all risks associated with product performance after installation. Rock Tamers™ will not protect everything and everyone from harm. Results may vary depending upon road surface and conditions, vehicle types, weather conditions, installation, and driving input. Please apply common sense to your expectations relating to product performance.

This product and its packaging contain chemicals known to the state of CA to cause cancer, birth defects or other reproductive harm.

Bolt Torque Conversion Table

| Inch-Pounds (in-lbs) | Foot-Pounds (ft-lbs) | Newton-Meters (N-m) | Kilogram-Centimeters (kgf-cm) |
|-------------------------|-------------------------|------------------------|----------------------------------|
| 20 | 1.7 | 2.3 | 23 |
| 30 | 2.5 | 3.4 | 34 |
| 70 | 5.87 | 7.9 | 79 |
| 80 | 6.7 | 9.0 | 90 |
| 180 | 15 | 20 | 203 |
| 1500 | 125 | 169 | 1690 |

Parts List for 00108/00110

| Part No. | Qty. | U/M | Description |
|------------------------------------|------|-----|---|
| RT034 | 1 | EA | Center Hub / Matte Black Finish* |
| RT035 | 2 | EA | M10 Ball Mount Clamp Bolt* |
| RT036 | 2 | EA | M10 Jam Nut* |
| RT037 | 2 | EA | M10 Split Washer* |
| RT038 | 2 | EA | M10 Flat Washer * |
| RT039 | 1 | EA | Hub Arm R (Right) / Matte Black Finish* |
| RT040 | 1 | EA | Hub Arm L (Left) / Matte Black Finish* |
| RT041 | 6 | EA | M6 Arm Clamp Bolt* |
| RT032 | 6 | EA | M6 Nylon Insert Hex Nut* |
| RT042 | 2 | EA | M18 Arm Pivot Bolt* |
| RT043 | 2 | EA | M18 Split Washer* |
| RT044 | 2 | EA | M18 Flat Washer* |
| RT027 | 1 | EA | 5mm Allen Wrench - Solid (Black) |
| RT045 | 2 | EA | Flap Support Rod (Stainless Sleeved) |
| RT046 | 2 | EA | Rod End Cap |
| RT017 | 2 | EA | Flap End Cap |
| RT018 | 2 | EA | M5 Flap Retainer Bolt (Round Head) |
| RT047 | 2 | EA | M5 End Cap Bolt (Hex Head) |
| RT019 | 4 | EA | M5 Nylon Insert Hex Nut |
| RT048 | 2 | EA | Flap Clamp / Matte Black Finish |
| RT022 | 2 | EA | Mudflap (SS Trim Plate) |
| RT023 | 10 | EA | M8 Flap Clamp Bolt |
| RT024 | 10 | EA | M8 Flat Washer |
| RT025 | 10 | EA | M8 Nylon Insert Hex Nut |
| RT026 | 1 | EA | Bolt Hole Punch (Black) |
| RT028 | 2 | EA | Rock Tamers Trim Plate |
| RT049 | 16 | EA | M6 Trim Plate Bolt (STAR PIN™) |
| RT030 | 16 | EA | M6 Trim Plate Spacer |
| RT031 | 16 | EA | M6 Flat Washer |
| RT032 | 16 | EA | M6 Nylon Insert Hex Nut |
| RT050 | 1 | EA | Locking STAR PIN™ Wrench (Black) |
| RT057 | 1 | EA | 2.5" Center Hub/Matte Black Finish.* (Only if 00110 is purchased.) |
| IM002 | 1 | EA | 00108/00110 Instruction Manual |
| * HUB ASSEMBLY - FACTORY ASSEMBLED | | | |

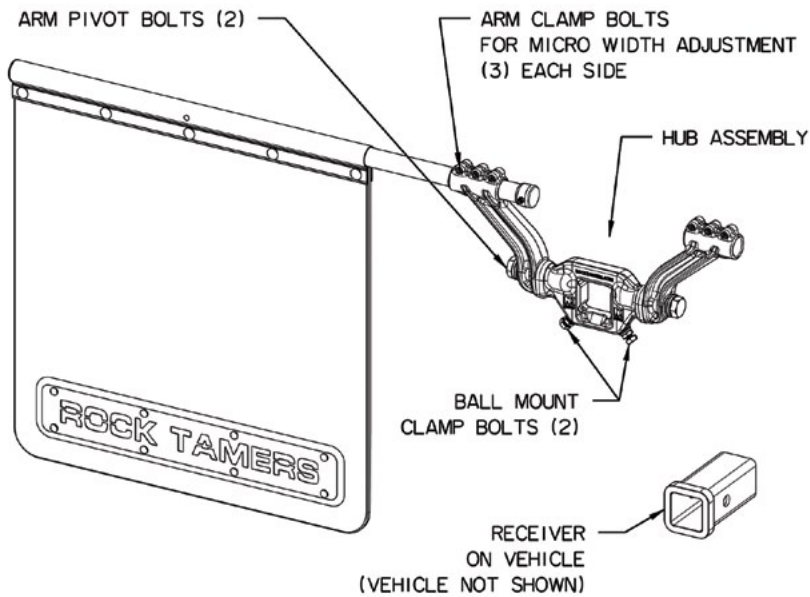
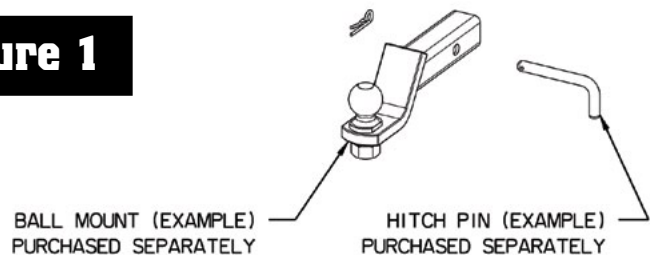
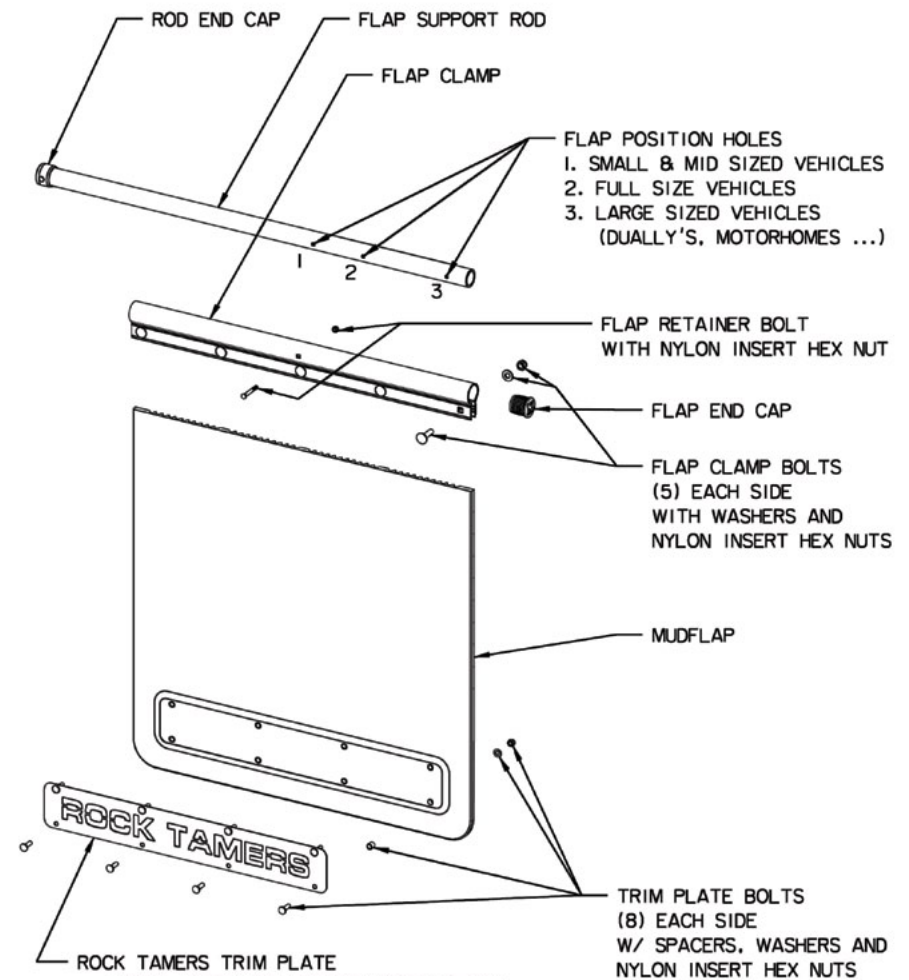

Figure 1



Assembly Hints

- Refer to **Figure 1** for component names and general definitions. Names in ALL CAPITALS refer to parts named in the illustrations.
- It may be easier to assemble the system while attached to a BALL MOUNT on the vehicle. However, it may also be assembled on a floor or workbench.
- **The MUDFLAP length may require cutting to fit your specific vehicle. Be sure of the required length by measuring with full tongue weight attached.**



Tools Required

- Wrench or socket sizes:
 - 8mm, 10mm, 13mm, 17mm, & 27mm (or a wrench adjustable up to 1 1/8" or 27mm)
 - Locking STAR PIN™ wrench included
 - 5mm locking Allen wrench included
- Utility knife
- Tape measure or yardstick.
- Straight edge for cutting guide at least 24" or 61 cm long
- Hammer or mallet

Assembly Instructions

Account for all parts listed in the Parts List.

1. Slide HUB ASSEMBLY onto BALL MOUNT and insert into vehicle RECEIVER HITCH. **See Figures 2 & 3.**

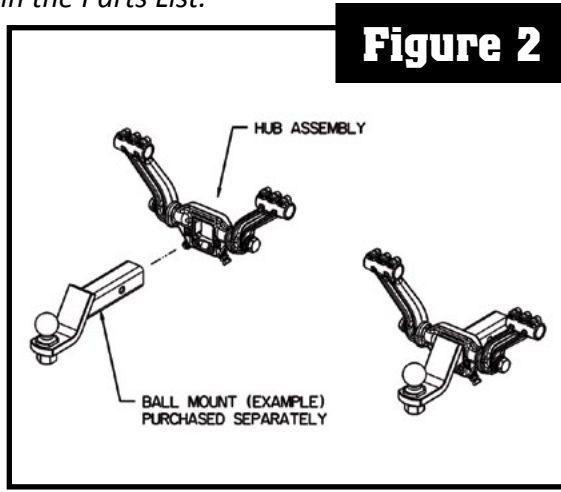

2. Secure the BALL MOUNT with HITCH PIN. Adjust HUB ASSEMBLY to desired position.

3. Tighten the two M10 BALL MOUNT CLAMP BOLTS to hold CENTER HUB in place. (For assembly only) **See Figure 3.**

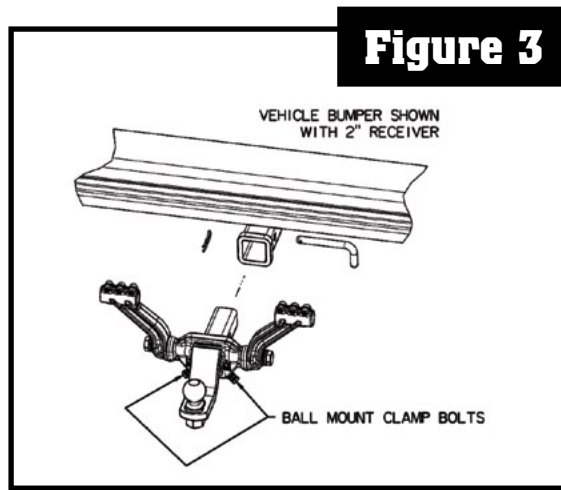

4. Loosen or Remove all three M6 ARM CLAMP BOLTS from each HUB ARM. Carefully insert the two FLAP SUPPORT RODS thru HUB ARMS. Place ROD END CAP over the end of rods, hex side facing away from vehicle, insert END CAP BOLT thru END CAP BOLT HOLE, tighten securely with M5 NYLON INSERT HEX NUT. **See Figure 4.**

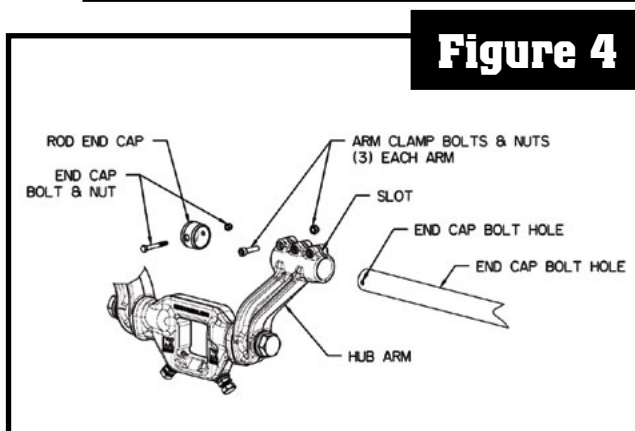

5. Re-install M6 ARM CLAMP BOLTS and M6 NYLON INSERT HEX NUTS back into HUB ARMS after the SUPPORT ROD is inserted. (Do not tighten yet.)
6. Position the left and right FLAP SUPPORT RODS so the width adjustment holes face forward horizontally. **Figure 5.**

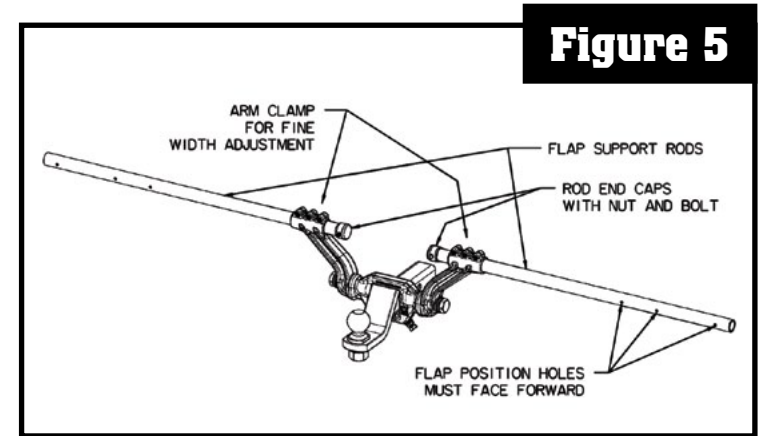

7. Slide FLAP CLAMPS over the FLAP SUPPORT RODS with square holes facing away from vehicle. Do not secure with FLAP RETAINER BOLTS yet. (See Figure 6 for orientation of flap retainer bolt hole and flap support rod positioning holes.) (Note: MUDFLAP not yet attached.) **Figure 6.**

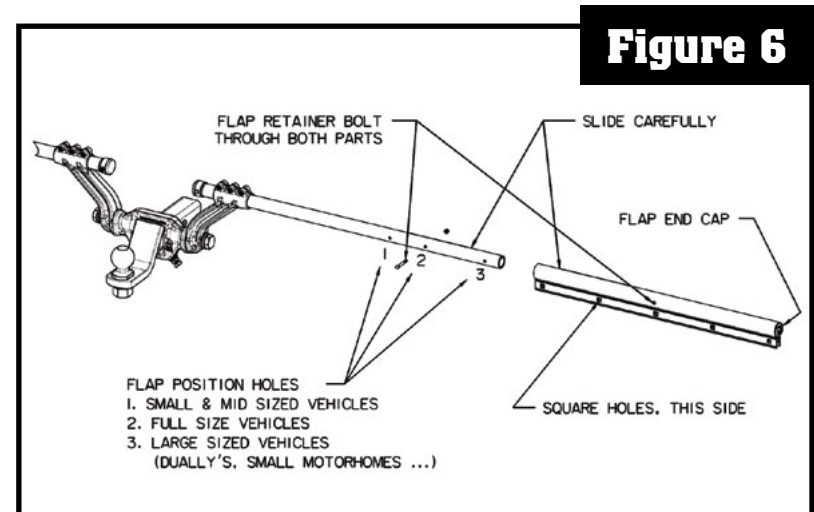

IMPORTANT: This next step is critical in ensuring that the MUDFLAP SYSTEM is properly installed. All measurements should be made while tow vehicle has full tongue weight.

8. Make sure SUPPORT RODS are level on both sides and measure the distance from the bottom of FLAP SUPPORT ROD to the ground. Subtract the desired ground clearance (3" - 4" recommended or 75 mm - 100 mm). *Figure 7.*

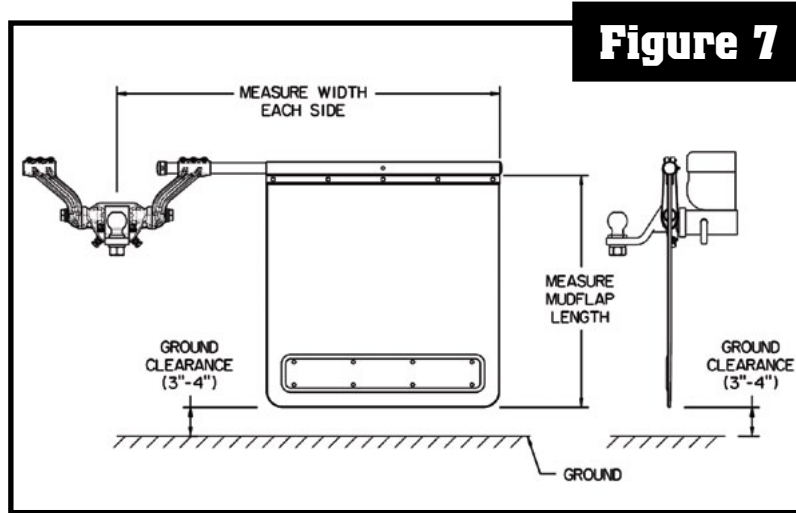

9. Lay MUDFLAP down with grooved side up on flat surface. Measure desired MUDFLAP length from the bottom up. Find the nearest pre-molded CUT LINE GROOVE and mark. *Figure 8.*

IMPORTANT: Before cutting and drilling/punching holes, make sure to place either a scrap piece of wood or thick cardboard underneath MUDFLAP to avoid any surface damage.

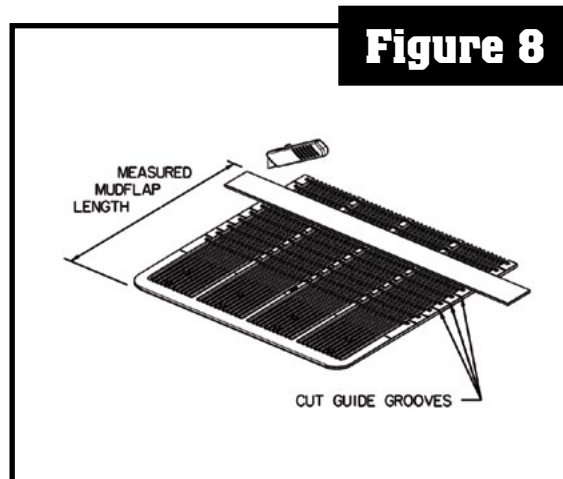

10. Use a sharp utility knife to cut through MUDFLAP using the groove and a straight edge as a guide. This may take several passes to completely cut through MUDFLAP. *See Figure 8.*

Repeat procedure for 2nd MUDFLAP.

IMPORTANT: Place a scrap piece of wood under the MUD FLAPS when punching or drilling holes, as the punch will dull and may damage the surface underneath.

11. Punch the top row of pre-molded holes in the MUDFLAP using the included BOLT HOLE PUNCH. *Figure 9.*

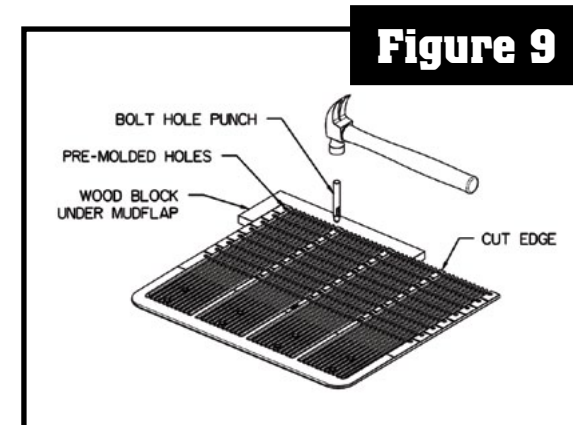

- Assemble cut end of MUDFLAP into FLAP CLAMP by either sliding or pushing it down onto top of MUDFLAP with the square holes on the smooth side.

Note: *Should it be difficult to slide MUDFLAP into FLAP CLAMP, moisten the cut end of MUDFLAP surface before inserting.*

Insert the five M8 FLAP CLAMP BOLTS through the square holes. Loosely attach the M8 FLAT WASHER and M8 NYLON INSERT HEX NUT to the back as shown. (Do not tighten yet.) **Figure 10.**

Repeat for 2nd MUDFLAP.

- Slide the FLAP CLAMP with attached MUDFLAP over the FLAP SUPPORT ROD with the NYLON INSERT HEX NUTS facing your vehicle.

Position the MUDFLAPS and FLAP SUPPORT RODS (left and right) as desired for your vehicle. Line up small hole in FLAP CLAMP with one of the three flap adjustment holes in SUPPORT ROD depending on vehicle size.

- Inner Hole - for small and mid-sized vehicles
- Center Hole - for full-size vehicles
- Outer Hole - for large vehicles, such as dually trucks and small motor homes

Finally, insert the small M5 FLAP RETAINER BOLT through FLAP CLAMP and SUPPORT ROD and attach the M5 NYLON INSERT HEX NUT. **Figures 1 & 6.**

Repeat for 2nd MUDFLAP.

- Assemble TRIM PLATES. Insert M6 TRIM PLATE SPACERS into holes in raised bottom portion of MUDFLAP. Attach the ROCK TAMERS TRIM PLATE with the eight M6 TRIM PLATE BOLTS (Locking STAR PIN™ [STAR PIN™ wrench included]), M6 FLAT WASHERS, and M6 NYLON INSERT HEX NUTS as shown in **Figure 10.** (20 in-lbs torque [10 mm socket or wrench]).

Repeat for 2nd MUDFLAP.

Note: *DO NOT over tighten, as it will damage the TRIM PLATE.*

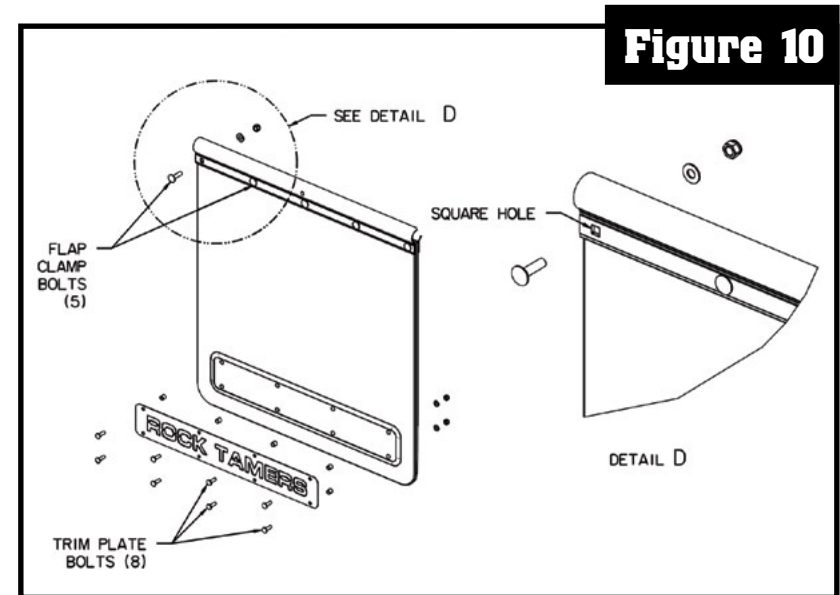

Figure 10

- The ARMS of the HUB ASSEMBLY may be loosened and rotated to fit your vehicle application. The FLAP SUPPORT RODS must also be rotated slightly so the MUDFLAPS hang vertical.

Figure 11.

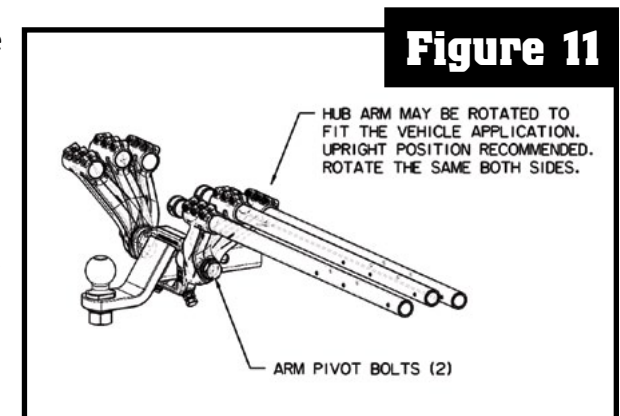

Figure 11

16. Finalize all positioning and adjustments. For all conversions see Torque conversion table on page 1.
17. Make sure the M10 SPLIT WASHERS and M10 JAM NUTS remain loose on the M10 BALL MOUNT CLAMP BOLTS and finish tightening the M10 CLAMP BOLTS evenly onto BALL MOUNT. (120-180 in-lbs torque [17 mm socket or wrench]).

Once the M10 BALL MOUNT CLAMP BOLTS are tight, tighten the M10 WASHERS AND JAM NUTS securely. **Figure 12.**

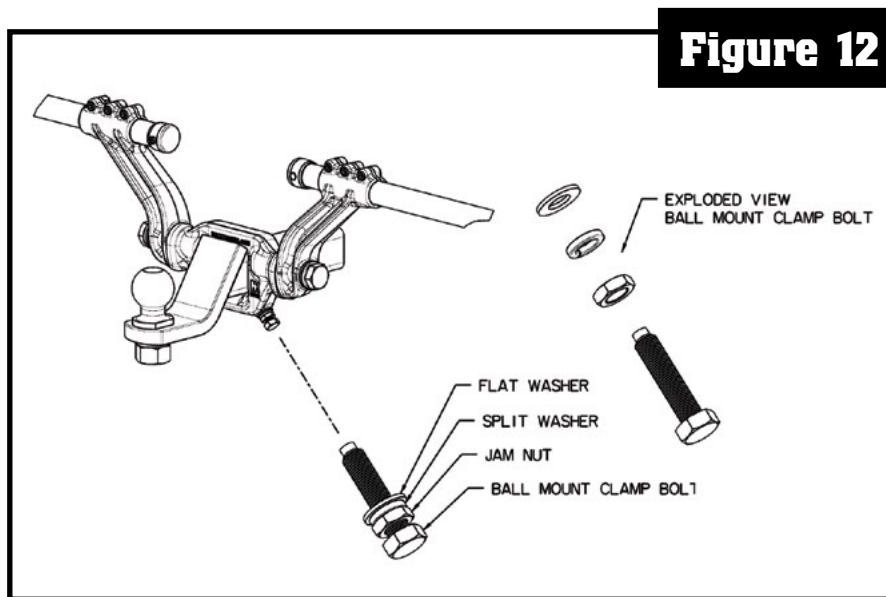

Figure 12

18. Tighten the large CENTER HUB M18 ARM PIVOT BOLTS. (1500 in-lbs torque [27mm socket or wrench]). **Figure 1.**

Note: Make sure the ARM PIVOT BOLTS and SUPPORT RODS have sufficient clearance away from the bumper so that they do not rub up against it.

19. Finalize width adjustment of FLAP SUPPORT RODS by sliding them in or out of the HUB ARMS. **Figure 5.**

Notes: It is recommended that final MUDFLAP position extends a minimum of 2" from outer edge of tire.

IMPORTANT: Evenly tighten the three M6 ARM CLAMP BOLTS beginning with the center bolt and moving from one to another on each side until all are tight. The SLOT will NOT close. (70-80 in-lbs torque [5mm ALLEN WRENCH]).

20. Tighten the five M8 FLAP CLAMP BOLTS on each of the FLAP CLAMPS. **Figure 10.** (30 in-lbs torque [13mm socket or wrench])

IMPORTANT: SUPPORT RODS MUST NOT BE ABLE TO ROTATE or MOVE IN HUB ARMS or FLAP CLAMPS.

21. Tighten the M5 FLAP RETAINER BOLTS on each side. **Figure 6**

IMPORTANT: FLAP RETAINER BOLTS are not intended to hold FLAP CLAMP on FLAP SUPPORT ROD. The RETAINER BOLTS must be used for proper positioning and safety.

22. Complete the assembly by inserting the FLAP END CAPS into the FLAP CLAMPS. **Figure 1.**

23. The ROCK TAMERS Mudflap System is now ready to use. As a final safety procedure, check bolts to see that they are tight and properly assembled. For optimum service and life, check components and the torque on all bolts prior to each use.

Figure 13.

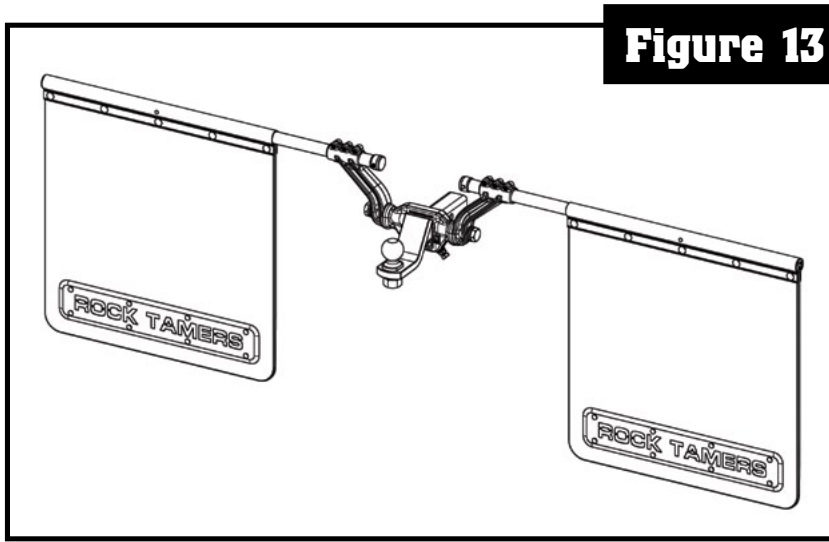

- > **FORGED ALUMINUM HUB & ARMS**
- > **STAINLESS SLEEVED STEEL RODS**
- > **UV PROTECTED MATTE BLACK FINISH**
- > **STAINLESS & CHROME PLATED HARDWARE**



LIMITED WARRANTY

Rock Tamers LLC warrants this product to be free of defects in material and workmanship under normal use and service for the period of one (1) year from the original consumer date of purchase. Rock Tamers LLC limits its obligation to repairing or replacing any part that proves defective in material or workmanship. A valid Return Goods Authorization (or RGA number) must be obtained from Rock Tamers LLC. Without this authorization number, no returns will be accepted and no credit can be issued. Any freight collect shipments will be refused. Rock Tamers LLC will pay return ground transportation charges only if the product is covered under this warranty. All returns must be shipped with TRANSPORTATION CHARGES PREPAID, to the address below, with a valid RGA number written clearly on the outside of the box:

Rock Tamers LLC 19475 Beacon Lite Road Monument, CO 80132 USA
Attn: Returns

This warranty does not extend to any product or part that is not installed and used in accordance with Rock Tamers LLC printed instructions, all applicable state and local regulations, and all applicable national standards and regulations, if any should apply. This warranty does not extend to any product or part that has been damaged by accident, misuse, abuse, or neglect, nor does it extend to any product or part that has been modified, altered, or repaired by the consumer. Except as expressly set forth above, and subject to, the limitation of liability below, Rock Tamers LLC makes NO OTHER WARRANTY, EXPRESS OR IMPLIED, INCLUDING, BUT NOT LIMITED TO, THE IMPLIED WARRANTIES OF MERCHANTABILITY AND FITNESS FOR A PARTICULAR PURPOSE, with respect to its products and parts, whether used alone or in combination with others. Rock Tamers LLC disclaims all warranties not stated herein.

LIMITATION OF LIABILITY

Rock Tamers LLC total liability for any and all losses and damages arising out of any cause whatsoever shall in no event exceed the purchase price of the products or parts in respect of which such cause arises, whether such cause be based on theories of contract, negligence, strict liability, tort or otherwise. Rock Tamers LLC shall not be liable for incidental, consequential or punitive damages or other losses. Rock Tamers LLC shall not be liable for, and consumer assumes liability for, all personal injury and property damage connected with the handling, transportation, possession, installation, other use or resale of the product, whether used alone or in combination with any other product or material. If Rock Tamers LLC furnishes technical advice to consumer, whether or not at consumer's request, with respect to installation, application, or use of the product and/or its related parts, Rock Tamers LLC shall not be liable for such technical advice and buyer assumes all risks of such advice and the results thereof. NOTE: Some states do not allow the limitation or exclusion of incidental or consequential damages, so the above limitations or exclusions, wholly or partially, may not apply. The portions of this limited warranty and limitation of liability shall be considered severable and all portions that are not disallowed by applicable law shall remain in full force and effect.

NOTICE TO CONSUMERS

All Rock Tamers LLC products are mechanical devices that will eventually show signs of wear, damage, corrosion, and aging of components made of materials such as rubber, etc. The environment and conditions of use will determine the safe service life of these products. Periodic inspection and maintenance are essential to retaining maximum efficiency of the product's shielding properties. Because of a policy of continuous product improvement, Rock Tamers LLC reserves the right to change designs, materials, or specifications without notice.



Rock Tamers LLC
19475 Beacon Lite Road, Monument, CO 80132
USA: 1-800-545-1894
For related accessories go to:

www.rocktamers.com

Follow us on:



WARNING: This product and its packaging contain chemicals known to the State of CA to cause cancer, birth defects or other reproductive harm.